

**MY  
TOP  
FONDOVALLE**



**MY  
TOP  
FONDOVALLE**



# General index

Indice generale  
 Índice général  
 Índice general  
 allgemeiner Index

4	<b>Introduction</b> Introduzione
6	<b>Sizes and thickness</b> Formati e spessore
12	<b>Technologies</b> Tecnologie
376	<b>Tech info</b> Informazioni tecniche

# Inspirations / Textures

Inspirations	Textures		Inspirations	Textures		Inspirations	Textures	
		<b>Infinito 2.0</b>	114	273	Capraia	191	335	Travertino Bianco
25	219	Magnus	116	289	Calacatta Light	195	337	Travertino Ebur
28	221	Mont Blanc	121	291	Calacatta Venice	198	339	Travertino Fuscus
32	223	Tundra Grey	122	287	Calacatta White	201	341	Jura White
34	225	Glacier	127	283	Statuario Extra	202	343	Chianca
37	227	Fantasy Dark	130	279	Elegant White	205	351	Slate Black
40	229	Calacatta Vagli Oro	132	297	Super White	206	349	Silver Stone
44	231	Vitrum Light	135	293	Calacatta Gold	209	347	Ceppo
47	233	Tiger	136	303	Green Denis			<b>Alpine</b>
50	235	Starlit	141	299	Calacatta Green	210	353	Alpine Light Grey Vein
53	237	Labradorite Royale	142	305	River Jade			<b>Planeto</b>
56	239	Calacatta Paris	146	309	Amazonite	355		Venus
61	241	Tiffany Green	150	311	Blue Roma	357		Jupiter
62	243	Meteor	153	307	Emerald Green	359		Pluto
67	275	Thassos	155	313	Agate Crystal Jade			<b>Portland</b>
68	277	Statuarietto	158	317	Agate Crystal Lace	63	361	Jordan
68	323	Black Pearl	161	315	Agate Blue Velvet	213	363	Hood
70	295	Calacatta Macchia Vecchia	164	319	Port Laurent	365		Tabor
73	247	Cream Diamonds	169	321	Pietra Grey			<b>Komi</b>
78	245	Cliff White	170	325	Sahara Noir	209	367	Elegant
83	267	Golden Spider		301	Zebrino	369		Original
86	251	Luxury Gold		285	Lincoln			<b>Monochrome</b>
90	249	Breccia Van Gogh		259	Onice White	371		White
94	263	Taj Mahal		281	Carrara C	373		Black
	261	Taj Mahal Light			<b>Stone Lab</b>			
97	253	Patagonia			175	345		
98	257	Fior Di Bosco			178	327		
103	255	Royal Creamy			181	329		
104	265	Gold River			184	331		
109	269	Rosso Lepanto			188	333		
110	271	Calacatta Viola						

Capaci di unire estetica, performance, praticità e lavorabilità le lastre ceramiche in gres porcellanato MyTop sono uno strumento duttile e completo a disposizione di designer e progettisti nel quale i ricercati design delle superfici vestono un materiale tecnologico e resistente, perfetta alternativa ai materiali tradizionali quali agglomerati plastici, pietre naturali, metalli.

## La natura come ispirazione, il design come destinazione.

Inspired by nature, design oriented.  
La nature comme inspiration, le design comme destination.  
La naturaleza como inspiración, el diseño como destino.  
Die Natur als Inspiration, das Design als Ergebnis.

Able to combine aesthetics, performance, practicality and workability, the MyTop porcelain stoneware ceramic slabs are a ductile and complete tool available to designers and creators in which the sophisticated designs of surfaces are cloaked in a technological and resistant material, the perfect alternative to traditional materials such as plastic agglomerates, natural stone and metals.

Capables de conjuguer esthétique, performances, praticité et maniabilité, les dalles en grès cérame MyTop constituent un outil ductile et complet à la disposition des concepteurs et des réalisateurs de projets, dont les designs raffinés des surfaces habillent un matériau technologique et résistant, une alternative parfaite aux matériaux traditionnels tels que les agglomérés plastiques, les pierres naturelles et les métaux.

Capaces de combinar estética, rendimiento, practicidad y trabajabilidad, las losas de gres porcelánico MyTop son una herramienta dúctil y completa a disposición de diseñadores y proyectistas en la que los refinados diseños de superficie visten un material tecnológico y resistente, una alternativa perfecta a materiales tradicionales como los aglomerados plásticos, las piedras naturales y los metales.

Die Natur als Inspiration, das Design als Ergebnis.  
Die Keramikplatten aus Feinsteinzeug My Top sind in der Lage, Ästhetik, Leistung, praktische Eigenschaften und Bearbeitbarkeit zu vereinen und sind ein flexibles und vollständiges Hilfsmittel für Designer und Planer, bei dem die raffinierten Designs der Oberflächen ein technologisches und widerstandsfähiges Material kleiden, das die perfekte Alternative zu herkömmlichen Materialien bildet, wie Kunststoffagglomeraten, Natursteinen und Metallen.



Nate dal design per il design, le lastre MyTop sono il risultato di un processo Made in Italy che unisce alle più avanzate tecnologie produttive sapienti lavorazioni artigianali. Il risultato è una superficie sinterizzata dalle altissime prestazioni tecniche, garanzia di sicurezza e resistenza che apre nuove frontiere progettuali al mondo dell'architettura e dell'arredo. Le lastre ceramiche in gres porcellanato a 12 e 20 mm di spessore sono particolarmente indicate per top di cucine, bagni, piani di lavoro, tavoli e arredi su misura. Diventano un'alternativa eccellente ad altri materiali come marmo, granito, alluminio, grazie alla durezza, igienicità, impermeabilità del gres porcellanato. Le lastre possono essere tagliate, lavorate e forate per adattarsi a molteplici utilizzi.

Born from design for design, the MyTop slabs are the result of an Italian manufacturing process that is combined with the most advanced and expert craft production technologies. The result is a sintered surface with the highest technical performance, guarantee of safety and resistance that opens up new design avenues to the world of architecture and furnishing. The porcelain stoneware ceramic slabs in the 12 and 20 mm thicknesses are particularly suitable for kitchen tops, bathrooms, work surfaces, tables and for custom furniture. They become an excellent alternative to other materials such as marble, granite and aluminium thanks to the hardness, hygiene properties and impermeability of porcelain stoneware. The slabs can be cut, worked and drilled to adapt to numerous uses.

Nées du design pour le design, les dalles MyTop sont le résultat d'un processus Made in Italy qui associe les technologies de production les plus avancées à des élaborations artisanales savantes. Le résultat est une surface frittée aux performances techniques très élevées, une garantie de sécurité et de résistance qui ouvre de nouvelles frontières de conception dans le monde de l'architecture et de la décoration. Les dalles en grès cérame de 12 et 20 mm d'épaisseur sont particulièrement indiquées pour les plans de cuisine et de salle de bains, les plans de travail, les dessus de tables et le mobilier sur mesure. Elles deviennent une excellente alternative à d'autres matériaux tels que le marbre, le granit et l'aluminium, grâce à la durabilité, à l'hygiène et à l'imperméabilité du grès cérame. Les dalles peuvent être coupées, façonnées et percées pour répondre à de nombreuses utilisations.

Nacidas del diseño por el diseño, las losas MyTop son el resultado de un proceso Made in Italy que combina las tecnologías de producción más avanzadas con un hábil trabajo artesanal. El resultado es una superficie sinterizada de altísimas prestaciones técnicas, garantía de seguridad y resistencia que abre nuevas fronteras de diseño al mundo de la arquitectura y el interiorismo. Las placas de gres porcelánico de 12 y 20 mm de espesor están especialmente indicadas para encimeras de cocina, baños, encimeras, mesas y muebles a medida. Se convierten en una excelente alternativa a otros materiales como el mármol, el granito o el aluminio, gracias a la durabilidad, higiene e impermeabilidad del gres porcelánico. Las placas pueden cortarse, mecanizarse y perforarse para adaptarse a múltiples usos.

Entstanden aus dem Design für das Design, sind Platten My Top das Ergebnis eines Prozesses Made in Italy, der handwerkliches Können mit den fortschrittlichsten Produktionstechnologien verbindet. Das Ergebnis ist eine gesinterte Oberfläche mit sehr hoher technischer Leistungsfähigkeit, die eine Garantie für Sicherheit und Beständigkeit ist, die der Welt der Architektur und Einrichtung neue Entwurfsgrenzen eröffnet. Die Keramikplatten aus Feinsteinzeug mit einer Stärke von 12 bis 20 mm eignen sich besonders als Tops für Küchen und Bäder, Arbeitsplatten, Tische und Einrichtungsgegenstände nach Maß. Sie werden durch ihre Haltbarkeit, Hygiene, Undurchlässigkeit des Feinsteinzeugs zu einer hervorragenden Alternative zu anderen Materialien, wie Marmor, Granit, Aluminium. Die Platten können geschnitten, bearbeitet und gebohrt werden, um vielfältigen Verwendungszwecken angepasst zu werden.

## Grandi formati, grandi possibilità.

Big on size, big on potential.  
De grands formats, de grandes possibilités.  
Grandes formatos, grandes posibilidades.  
Große Formate, große Möglichkeiten.

**12mm**

1/2"

**20mm**

3/4"

**163x324cm**

64,17"x127,56"

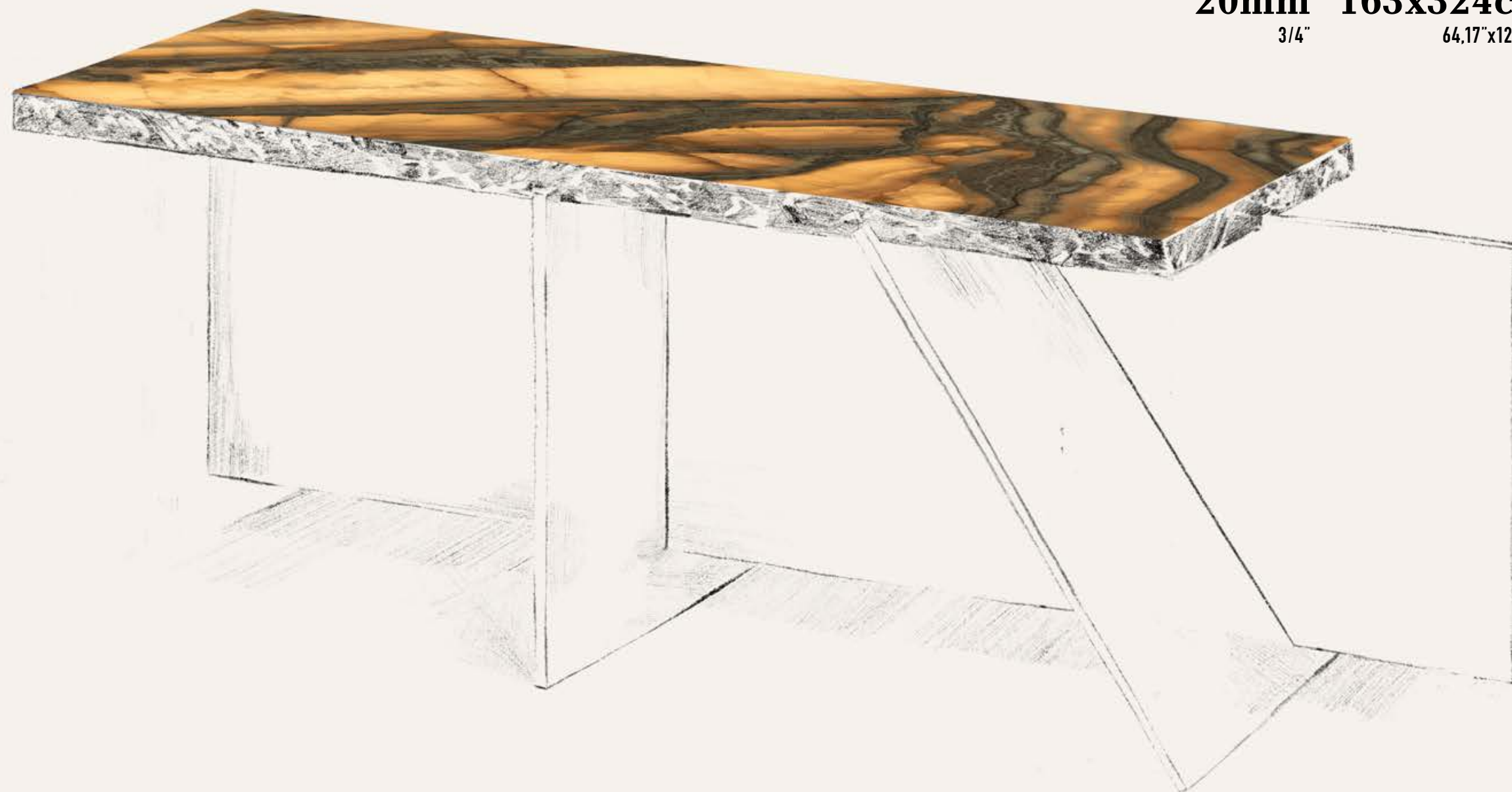



12 mm / 163x324 cm / Real Matt  
**Stone Lab Ceppo**  
FLOOR Homescape Sugar 120x120

Una sofisticata naturalezza è il tratto che unisce tutte le creazioni MyTop di Fondovalle, ispirate ai marmi, al cemento, alle pietre. Texture ricercate, trattate con lavorazioni artigianali e tecnologie rare, sono alla base di una riedizione della superficie ceramica in scala più ampia, che ne mantiene il valore estetico e pratico dal fascino duraturo.

## Ispirazioni materiche differenti che abbracciano le tendenze dell'interior design

Different material inspirations that embrace interior design trends.  
Différentes inspirations matériériste qui épousent les tendances de la décoration intérieure.  
Diferentes inspiraciones materiales que abrazan las tendencias del interiorismo  
Verschiedene Inspirationen der Materie widmen sich den Trends des Interior Designs.

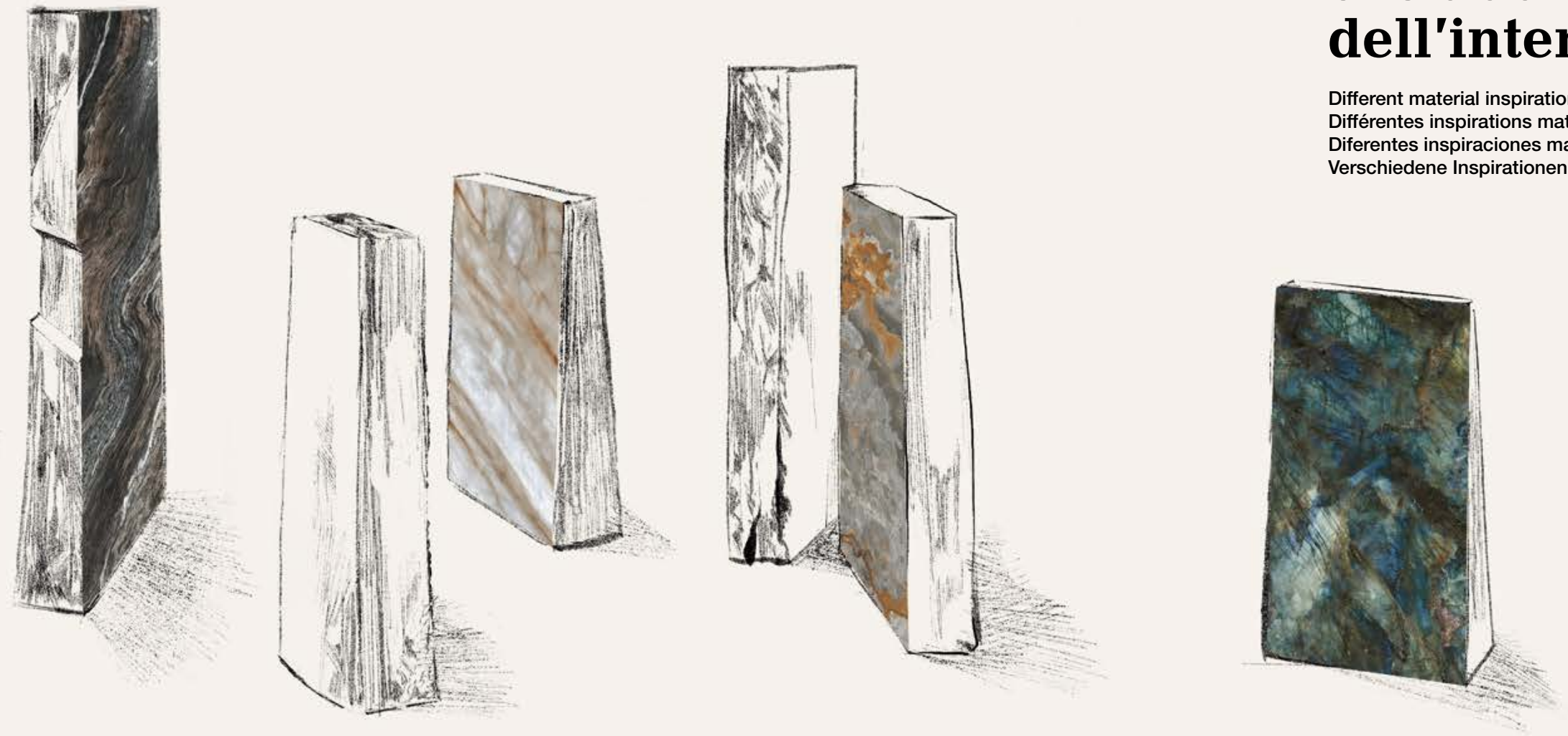

A sophisticated naturalness is the theme that unites all the MyTop creations of Fondovalle, inspired by marble, concrete and stones. Sought-after textures, processed with handcrafted workmanship and rare technologies, form the basis of a re-edition of the ceramic surface on a wider scale that preserves its aesthetic and practical value with a lasting beauty.

Un naturel sophistiqué est le trait qui unit toutes les créations MyTop de Fondovalle, inspirées du marbre, du béton, des pierres. Des textures raffinées, traitées selon des élaborations artisanales et des technologies rares, sont à la base d'une réédition de la surface céramique à plus grande échelle, qui en conserve la valeur esthétique et pratique à l'attrait durable.

Una sofisticada naturalidad es el rasgo que une todas las creaciones MyTop de Fondovalle, inspiradas en el mármol, el cemento y la piedra. Texturas refinadas, tratadas con artesanía y tecnologías poco comunes, son la base de una reedición de la superficie cerámica a mayor escala, que mantiene su valor estético y práctico con un atractivo duradero.

Allen Kreationen MyTop von Fondovalle, die vom Marmor, vom Beton und von Naturstein inspiriert sind, zeichnen sich durch ein gemeinsames Element aus: ihre raffinierte Natürlichkeit. Die ausgesuchten, durch seltene handwerkliche Bearbeitungen und Technologien behandelten Texturen sind die Grundlage einer Neuaufgabe der keramischen Oberfläche im weiteren Sinn, die neben Reinheit und Funktionalität einen zeitlosen Charme zu bewahren vermag.



## Effetto luminoso sofisticato e affascinante.

Sophisticated, enchanting luminous effect.  
Effet lumineux sophistiqué et captivant.  
Efecto luminoso sofisticado y fascinante  
Leuchteffekt von ausgesuchter Eleganz.

### Impatto visivo scenografico

Dramatic visual impact  
Impact visuel scénographique  
Impacto visual escenográfico  
Szenografische Wirkung

### Texture grafiche che emanano luminosità

Graphic textures with a luminous radiance  
Textures graphiques lumineuses  
Texturas gráficas que irradian luminosidad  
Grafische Texturen von leuchtender Ausstrahlung

### Superfici con mutevoli giochi di luce

Surfaces with varying interplays of light  
Surfaces avec des jeux de lumière changeants  
Superficies con cambiantes juegos de luz  
Oberflächen mit abwechslungsreichen Lichtspielen

L'effetto ALL-LIGHT, derivante da un sofisticato sviluppo grafico, **riproduce l'effetto di una retroilluminazione naturale** e dona alla superficie un effetto luminoso raffinato e suggestivo. L'impatto visivo, elegante e moderno, è ideale per i progetti d'interior design che si propongono in modo esclusivo e scenografico.

The ALL-LIGHT effect, derived from sophisticated graphic design, **reproduces the effect of natural backlighting** and gives the surface a luminous radiance of great loveliness. Its elegant, modern appearance is ideal for striking, luxurious interior design projects.

L'effet ALL-LIGHT, issu d'un développement graphique sophistiqué, **reproduit l'effet d'un rétroéclairage naturel**, offrant à la surface une luminosité raffinée et enchanteresse. L'impact visuel, élégant et moderne, est idéal pour les projets de design intérieur qui souhaitent se présenter de manière exclusive et scénique.

El efecto ALL-LIGHT, resultado de un sofisticado desarrollo gráfico, **reproduce el efecto de una retroiluminación natural** y confiere a la superficie un efecto luminoso refinado y sugestivo. El impacto visual, elegante y moderno, es ideal para proyectos de interiorismo que se presentan de forma exclusiva y esceno

Der ALL-LIGHT Effekt, dem eine aufwändige Designentwicklung zugrunde liegt, **ahmt eine natürliche Hinterleuchtung** nach und verleiht der Oberfläche eine reizvolle, leuchtende Ausstrahlung. Die elegante, moderne Optik ist ideal für Interior-Projekte, die auf eine exklusive und szenografische Wirkung setzen.

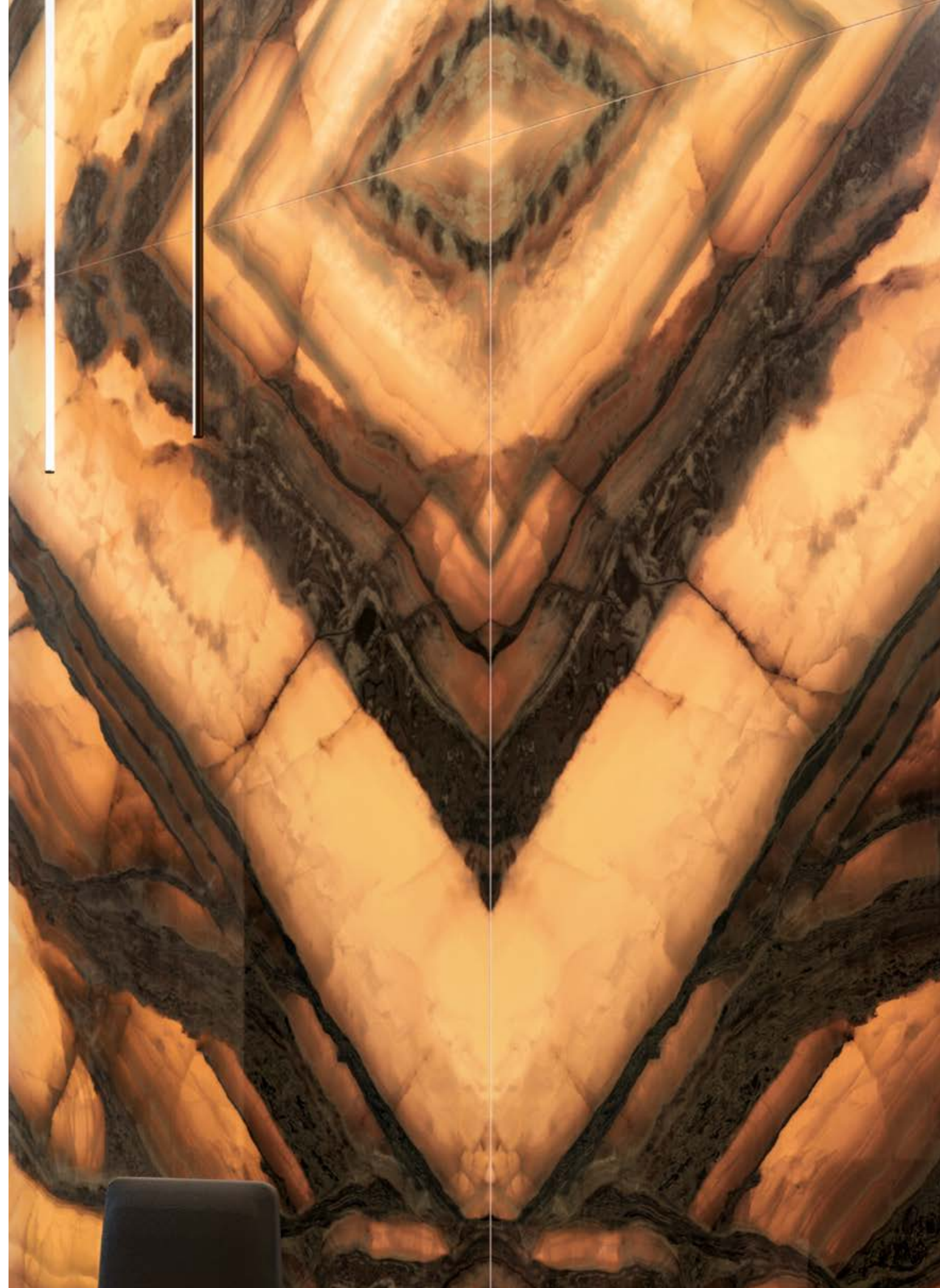

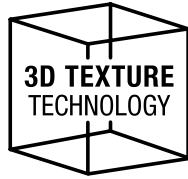

# Texture 3D dall'intenso realismo materico.

3D Texture with intense material realism.

Des textures matiéristes en 3D extrêmement réalistes.

Texturas 3D de gran realismo material.

3D-Oberflächen mit unglaublich realistischer Anmutung.

## Matericità tridimensionale

Three-dimensionality  
Effet matière tridimensionnel  
Materialidad tridimensional  
Dreidimensionales Materialbild

## Profondità di dettaglio

Depth of detail  
Profondeur des détails  
Profundidad de los detalles  
Sorgfältig ausgearbeitete Details

## Grande naturalezza e veridicità

Striking naturalness and realism  
Un grand naturel et une grande véracité  
Gran naturalidad y veracidad  
Natürlichkeit und Authentizität

Fondovalle inaugura una nuova era nella produzione del gres porcellanato grazie a 3D Texture, **una tecnologia digitale altamente innovativa che regala una matericità profonda**, generando un effetto tridimensionale sulle superfici, fedele all'essenza di ispirazione. La tecnologia 3D Texture consente una perfetta sincronia tra differenti applicazioni e materie con effetti di realismo e profondità di dettaglio straordinari. Il risultato è frutto di investimenti e assidua ricerca, e arricchisce di tridimensionalità l'impasto pressato, cromie e strutture coincidono sinergicamente e le superfici acquistano un'autentica veridicità percepibile sia al tatto che alla vista.

Fondovalle is heralding a new era in the production of porcelain stoneware thanks to 3D Texture, **a highly innovative digital technology that offers a deep material quality**, producing a three-dimensional effect on surfaces to accurately resemble the wood that inspired them. 3D Texture technology permits perfect synchronisation between different applications and materials with extraordinarily realistic effects and depth of detail. The result is the fruit of investment and painstaking research, enhancing the three-dimensionality of the pressed mix; colours and textures synergistically harmonise and the surfaces acquire an authenticity perceptible to both touch and sight.

Avec Fondovalle, la production de grès cérame entre dans une nouvelle ère grâce à 3D Texture, **une technologie numérique tout à fait innovante qui apporte un rendu fortement matiériste**, en créant un effet tridimensionnel sur les surfaces, parfaitement fidèle à l'essence dont elle s'inspire. La technologie 3D Texture permet une synchronisation parfaite entre les différentes applications et matières, avec d'extraordinaires effets de réalisme et de profondeur du détail. Fruit d'un investissement et d'une recherche assidue, le résultat enrichit la pâte pressée d'un effet tridimensionnel. Les couleurs et les structures coïncident en synergie et les surfaces acquièrent une véracité authentique perceptible non seulement à la vue mais aussi au toucher.

Fondovalle inaugura una nueva era en la producción de gres porcelánico gracias a 3D Texture, **una tecnología digital altamente innovadora que aporta una profunda materialidad**, generando un efecto tridimensional en las superficies, fiel a la esencia de la inspiración. La tecnología 3D Texture permite una sincronización perfecta entre diferentes aplicaciones y materiales con efectos de realismo y extraordinaria profundidad de detalle. El resultado es fruto de la inversión y la investigación asidua, y enriquece la mezcla prensada con tridimensionalidad, los colores y las texturas coinciden sinérgicamente y las superficies adquieren una auténtica veracidad perceptible tanto al tacto como a la vista.

Dank der hochinnovativen Digitaltechnik 3D Texture, **die eine besondere Materialtiefe erzeugt, eröffnet Fondovalle ein neues Kapitel in der Produktion von Feinsteinzeug**. Oberflächen mit plastischer Wirkung geben das zum Vorbild dienende Material äußerst getreu wieder. Die Technik 3D Texture ermöglicht eine vollkommen synchrone Erzeugung von Struktur und Dekor, wodurch eine ungewöhnlich realistische Wirkung und hohen Detailtiefe erzielt wird. Dank Investitionen und intensiver Forschungstätigkeit gelang es, der gepressten Masse eine besondere Tiefenoptik zu verleihen. Durch die passgenaue Übereinstimmung zwischen Farbauftrag und Struktur geben die Oberflächen haptisch wie optisch ein täuschend echtes Bild der Vorlage wieder.





# Preziosità infinita di brillante splendore.

Splendidly bright and infinitely precious.  
Raffinement infini à l'éclatante splendeur.  
Preciosidad sin fin de brillante esplendor.  
Die unendliche Kostbarkeit strahlenden Glanzes.

## Superfici più luminose e profonde

Brighter, deeper surfaces  
Des surfaces plus lumineuses, plus profondes  
Superficies más brillantes y profundas  
Leuchtendere und plastischere Oberflächen

La tecnologia Crystal arricchisce le superfici di una particolare trasparenza e luminosità, generata da una miscela preziosa di minuscole particelle di cristalli e pigmenti perlescenti che crea infinite e mutevoli rifrazioni luminose. Le texture grafiche appaiono visibilmente più brillanti e acquisiscono profondità. Grazie a questa tecnologia le superfici presentano mutevoli effetti cangianti che variano in base alla luce, generando un effetto di prezioso splendore.

The Crystal technology enriches surfaces with a special shine and transparency, generated by a precious mix of tiny particles of crystals and pearly pigments, refracting the light in an infinity of constantly changing ways. The patterning textures acquire vastly greater brightness and depth. This technology gives surfaces iridescence that changes with the light, generating an effect of exquisite splendour.

## Texture con mutevoli effetti di trasparenza

Textures with ever-changing transparency  
Des textures aux effets de transparence changeants  
Texturas con efectos de transparencia cambiantes  
Texturen mit facettenreichen Transparenzen

Raffinement infini à l'éclatante splendeur La technologie Crystal enrichit les surfaces d'une transparence et d'une luminosité particulières, que génère un mélange précieux de minuscules particules de cristal et de pigments nacrés, créant des réfractions lumineuses infinies et changeantes. Apparaissent visiblement plus brillantes, les textures graphiques gagnent en profondeur. Grâce à cette technologie, les surfaces présentent des effets irisés changeants, qui varient en fonction de la lumière et créent un effet de précieuse splendeur.

## Riflessi di luce e ombra cangianti

Iridescent light and shade effects  
Des reflets changeants d'ombre et de lumière  
Reflejos de luz y sombras iridescentes  
Changierende Licht- und Schattenspiele

La tecnología Crystal enriquece las superficies con una transparencia y luminosidad especiales, generadas por una preciosa mezcla de diminutas partículas de cristal y pigmentos nacarados que crean refracciones de luz infinitas y siempre cambiantes. Las texturas gráficas aparecen visiblemente más brillantes y ganan profundidad. Gracias a esta tecnología, las superficies presentan efectos iridiscientes cambiantes que varían según la luz, generando un efecto de precioso resplandor.

Die Crystal-Technologie verleiht Oberflächen eine besondere Transparenz und Ausstrahlungskraft, die auf der kostbaren Mischung feinsten Kristallpartikel und perlmuttfarben schimmernder Pigmente beruhen, die einen facettenreichen Glanz erzeugen. Die grafischen Texturen treten leuchtend hervor und erhalten mehr Tiefe. Dank dieser Technologie changiert die Oberfläche je nach Einfallswinkel des Lichts in einem prachtvoll glänzenden Farbspiel.

ALL-OVER è una tecnica che permette di riportare la texture della lastra ceramica anche sul bordo, ristampata digitalmente sulla porzione di superficie selezionata, in maniera fedelissima alla grafica di partenza. Questa lavorazione è frutto di una tecnologia produttiva innovativa, concessa in esclusiva a Fondovalle e oggetto di domanda di brevetto, capace di creare un effetto materico delle superfici in gres porcellanato molto più realistico, mantenendo una continuità di texture che dal piano scende e prosegue lungo tutto lo spessore.



## Una continuità estetica senza precedenti per superfici che sanno distinguersi.

Exclusive aesthetic continuity for surfaces that know how to stand out  
Une continuité esthétique sans précédent pour des surfaces qui savent se démarquer  
Una continuidad estética sin precedentes para superficies que saben distinguirse  
Eine bisher nie erzielte einheitliche Optik für Flächenbeläge der besonderen Art

ALL-OVER is a technique that also allows the texture of the ceramic slab to be reproduced on the edge, digitally reprinted on the selected portion of the surface in a way that is very faithful to the original graphic. This process is the result of an innovative production technology – exclusively granted to Fondovalle and the subject of a patent application – that creates a much more realistic textural effect on porcelain stoneware surfaces, maintaining a continuous texture that descends from the top and continues throughout the thickness.

ALL-OVER est une technique qui permet de reproduire la texture de la dalle céramique jusque sur le bord, en réimprimant numériquement la partie sélectionnée de la surface, dans une réplique tout à fait conforme au graphisme d'origine. Ce traitement est le résultat d'une technologie de production innovante, accordée à titre exclusif à Fondovalle et faisant l'objet d'une demande de brevet. Il permet de créer un effet de matière beaucoup plus réaliste sur les surfaces en grès cérame, en maintenant une continuité de texture qui descend du dessus pour se poursuivre sur toute l'épaisseur.

ALL-OVER es una técnica que permite reproducir la textura de la losa cerámica también en el borde, reimpresa digitalmente en la porción seleccionada de la superficie, de forma muy fiel a la gráfica original. Este proceso es el resultado de una tecnología de producción innovadora, concedida en exclusiva a Fondovalle y objeto de una solicitud de patente, capaz de crear un efecto de textura mucho más realista en las superficies de gres porcelánico, manteniendo una continuidad de textura que desciende desde la parte superior y continúa a lo largo de todo el grosor.

ALL-OVER ist eine Technik, die es ermöglicht, die Textur der Keramikplatte auch auf der Kante wiederzugeben. Per digitalem Druck wird also Oberflächenbild getreu auf diesem Plattenteil reproduziert. Möglich ist dies durch ein innovatives, exklusiv von Fondovalle genutztes Produktionsverfahren, das Gegenstand einer Patentanmeldung ist. Durch die von der Plattenoberseite auf die gesamte Kante übergehende Textur erhält das Feinsteinzeug eine unvergleichlich realistische Materialoptik.





ALL-OVER è stata pensata in particolar modo per rifinire tavoli e mobili della collezione Shape, ma si presta potenzialmente a valorizzare qualsiasi complemento di arredo custom-made o può essere applicata per rifinire dettagli architettonici, oggettistica e progetti di design in cui viene richiesta la massima cura del dettaglio. L'effetto di ALL-OVER ripropone ciò che avviene in natura nelle pietre naturali che si distinguono per le loro variazioni, soprattutto se si considera la superficie orizzontale della lastra rispetto alla costa dove la vena è tagliata trasversalmente ed è quindi, a volte, diversa.



## Infinite applicazioni in ambito residenziale e commerciale.

Infinite applications in residential and commercial locations  
 Une infinité d'applications en résidentiel et en commercial  
 Infinitas aplicaciones residenciales y comerciales  
 Mannigfaltige Anwendungsmöglichkeiten  
 im Wohn- und Objektbereich

ALL-OVER has been especially designed to finish tables and furniture from the Shape collection, but it can potentially be used to enhance any custom-made furniture accessory or applied to finish architectural details, objects and design projects that require the utmost attention to detail. The All-Over look accurately reproduces the effects that occur in the environment with natural stones and their rich variations, especially between the horizontal surfaces of slabs and the edges, which cut through the veining, meaning that the patterning is sometimes different.

ALL-OVER a été spécialement conçue pour la finition des tables et des meubles de la collection Shape, mais elle peut être utilisée pour valoriser n'importe quel élément de décoration sur mesure ou pour la finition de détails architecturaux, d'objets et de projets de design où il est fondamental d'apporter le plus grand soin aux moindres détails. L'effet All-Over reproduit la création de la nature sur les pierres naturelles : des variations typiques, notamment sur la surface horizontale de la dalle par rapport à la tranche, où, du fait de la coupe transversale, la veine est parfois différente.

ALL-OVER se ha diseñado especialmente para el acabado de mesas y muebles de la colección Shape, pero puede utilizarse potencialmente para realzar cualquier accesorio de decoración hecho a medida o puede aplicarse para el acabado de detalles arquitectónicos, objetos y proyectos de diseño en los que se requiera la máxima atención al detalle. El efecto de ALL-OVER reproduce lo que ocurre en la naturaleza en las piedras naturales, que se distinguen por sus variaciones, especialmente si se considera la superficie horizontal de la losa en relación con la nevadura, donde la veta se corta transversalmente y, por tanto, a veces es diferente.

ALL-OVER wurde speziell für die saubere Ausführung der Tische und Möbel der Kollektion Shape konzipiert, kann sich jedoch auch für die Gestaltung maßgefertigter Einrichtungselemente, Detaillösungen und Wohnaccessoires sowie für die Umsetzung von Designprojekten verwendet werden, bei denen es auf fein ausgearbeitete Details ankommt. All-Over bringt Naturstein in seinem ganzen Facettenreichtum zur Geltung, und zwar in der Fortsetzung des Materialbildes der horizontalen Oberfläche auf der Kantenfläche der keramischen Platte, wo die Äderung eine andere Schnittfläche und deshalb bisweilen eine andere Gestalt aufweist.

**Porcelain stoneware slabs**  
 Lastre in gres porcellanato  
 Grès cérame plaques  
 Placas de gres porcelánico  
 Feinsteinzeugs platten

6 mm / 8,5 mm / 12 mm / 20 mm

Per maggiori informazioni sulla tecnologia ALL-OVER, consultare il catalogo dedicato | For more information on ALL-OVER technology, see the dedicated catalogue | Pour de plus amples informations sur la technologie ALL-OVER, voir le catalogue dédié | Para mayores informaciones sobre la tecnología ALL-OVER, sírvase consultar el catálogo específico | Ausführliche Informationen zur ALL-OVER Technologie finden Sie im betreffenden Katalog

**Kitchen Top**  
Top Cucina

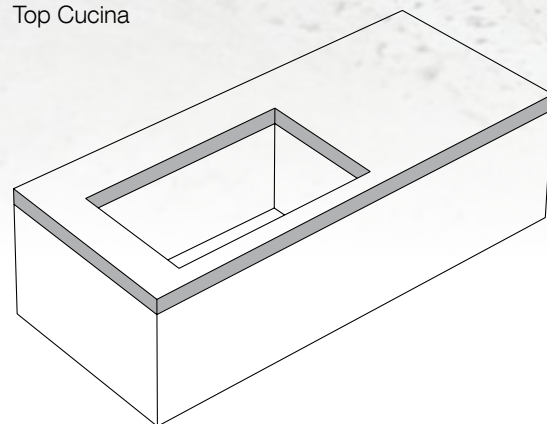

**Shelves and furniture**  
Mensole e mobili

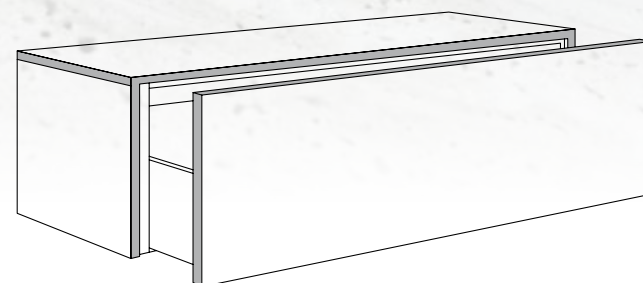

**Bathrooms Top**  
Top bagni

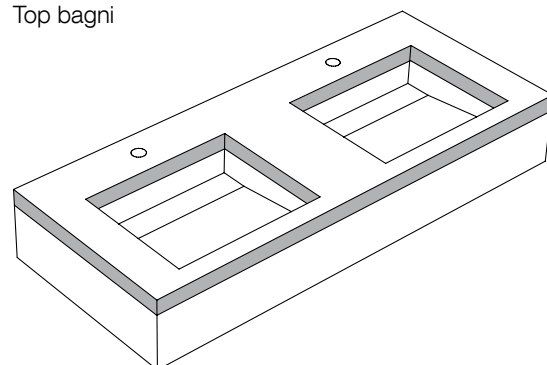

**Tables**  
Tavoli

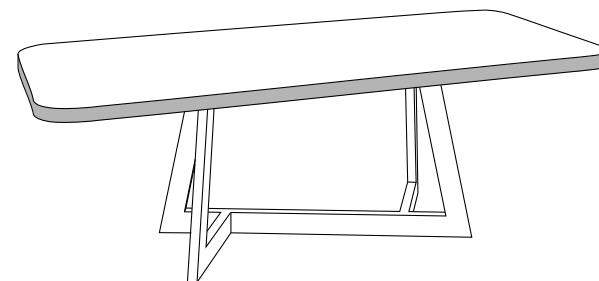

---

## INSPIRATIONS: INFINITO 2.0

ISPIRAZIONI: INFINITO 2.0

La collezione Infinito 2.0 raccoglie una ricercata selezione di marmi naturali, trasformati in sorprendenti superfici in gres porcellanato dalle potenziate qualità tecniche ed estetiche. Continuità di toni, venature calibrate, finiture lucide e opache trasformano la materia “marmo” in un prodotto versatile, capace di incontrare le rinnovate esigenze della progettazione contemporanea.

The Infinito 2.0 collection brings together a stylish assortment of natural marbles, recreated in stunning porcelain stoneware offering enhanced technical and aesthetic features. Continuity of tones, balanced veining, glossy and matt finishes, turn “marble” into a versatile product that meets the ever-changing needs of contemporary design. This faithful reproduction of the most prized varieties of marble lends a unique appeal to any setting.

La collection Infinito 2.0 réunit une sélection raffinée de marbres naturels, transformés en surprenantes surfaces de grès cérame avec des qualités techniques esthétiques améliorées. La continuité des tons, les veines calibrées, les finitions brillantes et mates transforment la matière « marbre » en un produit polyvalent, capable de répondre aux exigences renouvelées de la conception contemporaine.

La colección Infinito 2.0 reúne una refinada selección de mármoles naturales, transformados en sorprendentes superficies de gres porcelánico con cualidades técnicas y estéticas mejoradas. Continuidad de tonos, veteados calibrados, acabados brillantes y mates transforman el material «mármol» en un producto versátil, capaz de responder a las renovadas exigencias del diseño. contemporáneo.

Die Kollektion Infinito 2.0 umfasst eine auserlesene Auswahl von natürlichen Marmoren, die in überraschende Oberflächen aus Feinsteinzeug mit verbesserten technischen und ästhetischen Eigenschaften umgewandelt wurden. Kontinuität der Farbtöne, kalibrierte Aderungen, glänzende und matte Oberflächen machen die Materie “Marmor” zu einem vielseitigen Produkt, das in der Lage ist, die neuen Erfordernisse des modernen Entwurfs zu erfüllen.

### Infinito 2.0

p.25  
Magnus  
p.28  
Mont Blanc  
p.32  
Tundra Grey  
p.34  
Glacier  
p.37  
Fantasy Dark  
p.40  
Calacatta Vagli Oro  
p.44  
Vitrum Light  
p.47  
Tiger  
p.50  
Starlit  
p.53  
Labradorite Royale  
p.56  
Calacatta Paris

p.61  
Tiffany Green  
p.62  
Meteor  
p.67  
Thassos  
p.68  
Statuarietto  
p.68  
Black Pearl  
p.70  
Calacatta Macchia Vecchia  
p.73  
Cream Diamonds  
p.78  
Cliff White  
p.83  
Golden Spider  
p.86  
Luxury Gold

p.90  
Breccia Van Gogh  
p.94  
Taj Mahal  
p.97  
Patagonia  
p.98  
Fior Di Bosco  
p.103  
Royal Creamy  
p.104  
Gold River  
p.109  
Rosso Lepanto  
p.110  
Calacatta Viola  
p.114  
Capraia  
p.116  
Calacatta Light

p.121  
Calacatta Venice  
p.122  
Calacatta White  
p.127  
Statuario Extra  
p.130  
Elegant White  
p.132  
Super White  
p.135  
Calacatta Gold  
p.136  
Green Denis  
p.141  
Calacatta Green  
p.142  
River Jade  
p.416  
Amazzonite

p.150  
Blue Roma  
p.153  
Emerald Green  
p.155  
Agate Crystal Jade  
p.158  
Agate Crystal Lace  
p.161  
Agate Blue Velvet  
p.164  
Port Laurent  
p.169  
Pietra Grey  
p.170  
Sahara Noir

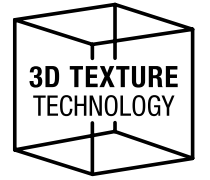

## Infinito 2.0 Magnus

**Ispirato al marmo italiano di altissimo pregio, con calde macchie di colore rosso/marrone e venature irregolari.**

Inspired by exquisite Italian marble, featuring warm red/brown flecks and unique veining.  
Inspiré du marbre italien de très haute qualité, avec des taches chaudes de couleur rouge/marron et un veinage irrégulier.

Inspirado en el mármol italiano de altísima calidad, con cálidos puntos de color rojo/marrón y vetas irregulares.  
Inspiriert vom italienischen Marmor höchster Qualität, mit warmen rot/braunen Farbflecken und unregelmäßigen Aderungen.

**12 mm  
163x324 cm**

**Available Finishes:  
Polished  
Full 3D Texture**

12 mm / 163x324 cm / Full 3D Texture  
**Infinito 2.0 Magnus**



12 mm / 163x324 cm / Full 3D Texture  
**Infinito 2.0 Magnus**  
FLOOR Komi Natural 40x240 / 24x240

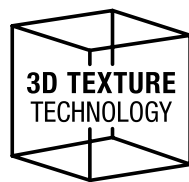

## Infinito 2.0 Mont Blanc

**Raffinata eleganza di un bianco caldo e luminoso,  
attraversato da delicate venature grigie.**  
The sophisticated elegance of a warm, bright white,  
laced with delicate grey veining.  
Une élégance raffinée d'un blanc chaud et lumineux,  
traversé de délicates veines grises.  
Refinada elegancia de un blanco cálido y luminoso  
atravesado por delicadas vetas grises.  
Raffinierte Eleganz eines warmen, leuchtenden Weißes,  
durchzogen von zarten grauen Aderungen.

**12 mm  
163x324 cm**

**Available Finishes:  
Crystal Polished  
Full 3D Texture**



12 mm / 163x324 cm / Full 3D Texture  
Infinito 2.0 Mont Blanc



12 mm / 163x324 cm / Crystal Polished  
**Infinito 2.0 Mont Blanc**  
FLOOR Slaten Stone Concrete 120x120

# Infinito 2.0 Tundra Grey

**Una texture dinamica dalla grande profondità  
impreziosita da riflessi colore oro e rame.**

A rich vibrant texture enhanced by gold and copper accents.  
Une texture dynamique, d'une grande profondeur,  
sublimée par des reflets dorés et cuivrés.  
Una textura dinámica de gran profundidad,  
embellecida por reflejos color oro y cobre.  
Eine dynamische Textur mit großer Tiefe,  
veredelt durch gold- und kupferfarbene Reflexe.

**12 mm  
163x324 cm**

**Available Finishes:  
Polished**



12 mm / 163x324 cm / Polished  
**Infinito 2.0 Tundra Grey**

FLOOR Komi Classic 40x240 / 24x240

Furniture SHAPE\_OMIK COFFEE 117x56\_barrel top:  
Infinito 2.0 Tundra Polished / Nero Gofirato

# Infinito 2.0 Glacier

**Un sapiente mix di toni bianco-grigi, una superficie ricca di dettagli dall'estetica profonda.**  
A masterful blend of whites and greys for a richly detailed surface that evokes depth and beauty.  
Un savant mélange de tons blanc-gris, une surface riche en détails à l'esthétique profonde.  
Una sapiente combinación de tono blanco/grises, una superficie rica en detalles de estética profunda.  
Eine geschickte Mischung aus Weiß- und Grautönen, eine Oberfläche reich an Details mit tiefer Ästhetik.



12 mm / 163x324 cm / Full 3D Texture  
**Infinito 2.0 Glacier**



**12 mm**  
**163x324 cm**

**Available Finishes:**  
**Full 3D Texture**



12 mm / 163x324 cm / Full 3D Texture  
**Infinito 2.0 Glacier**

FLOOR Slaten Stone White 120x120

Furniture SHAPE\_DOUBLE TRACE 150X45:  
Infinito 2.0 Glacier Full 3D Texture

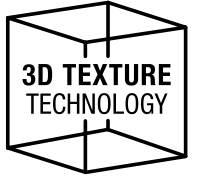

## Infinito 2.0 Fantasy Dark

**Venature ondulate e sinuose che creano una raffinata eleganza sui toni scuri.**  
Winding, wavy veining set against dark tones lends a sophisticated elegance.  
Des veines ondulées et sinueuses qui créent une élégance raffinée sur les tons sombres.  
Vetas onduladas y sinuosas que crean una refinada elegancia sobre tonos oscuros.  
Geschwungene und kurvige Aderungen, die auf dunklen Tönen eine raffinierte Eleganz erzeugen.

**12 mm  
163x324 cm**

**Available Finishes:  
Full 3D Texture**

12 mm / 163x324 cm / Full 3D Texture  
Infinito 2.0 Fantasy Dark



12 mm / 163x324 cm / Full 3D Texture  
**Infinito 2.0 Fantasy Dark**  
FLOOR Slaten Stone Beige 120x120

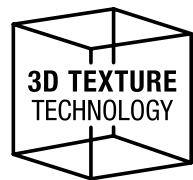

## Infinito 2.0 Calacatta Vagli Oro

**Venature oro e tortora ampie e sinuose.**  
Large and sinuous gold and turtledove veins.  
Veines or et taupe, amples et sinueuses.  
Vetas doradas y gris ceniciento amplias y sinuosas.  
Großzügigen, weit geschwungenen gold- und taupefarbenen.

**12 mm  
163x324 cm**

**Available Finishes:  
Full 3D Texture  
Polished**

12 mm / 163x324 cm / Full 3D Texture  
**Infinito 2.0 Calacatta Vagli Oro**



12 mm / 163x324 cm / Full 3D Texture

**Infinito 2.0 Calacatta Vagli Oro**

FLOOR Slaten Stone Sand 60x120

WALL Slaten Stone Sand 120x278 / Slaten Stone Sand GEO 60x120

Furniture SHAPE\_RAKI ROUND Ø 156:

Infinito 2.0 Calacatta Vagli oro Full 3D Texture / Nero Satin

## Infinito 2.0 Vitrum Light

Un effetto quarzite eterno che dona alla superficie una luminosa e apparente trasparenza.

A timeless quartzite effect lends these tiles a brightness bordering on translucent.

Un effet quartzite éternel qui donne à la surface une transparence lumineuse et apparente.

Un efecto cuarcita eterno que confiere a la superficie una luminosa y aparente transparencia.

Ein ewiger Quarzit-Effekt, der der Oberfläche eine leuchtende und scheinbare Transparenz verleiht.

12 mm  
163x324 cm

Available Finishes:  
ALL-LIGHT Polished



12 mm / 163x324 cm / ALL-LIGHT Polished  
Infinito 2.0 Vitrum Light  
FLOOR Komi Elegant 40x240

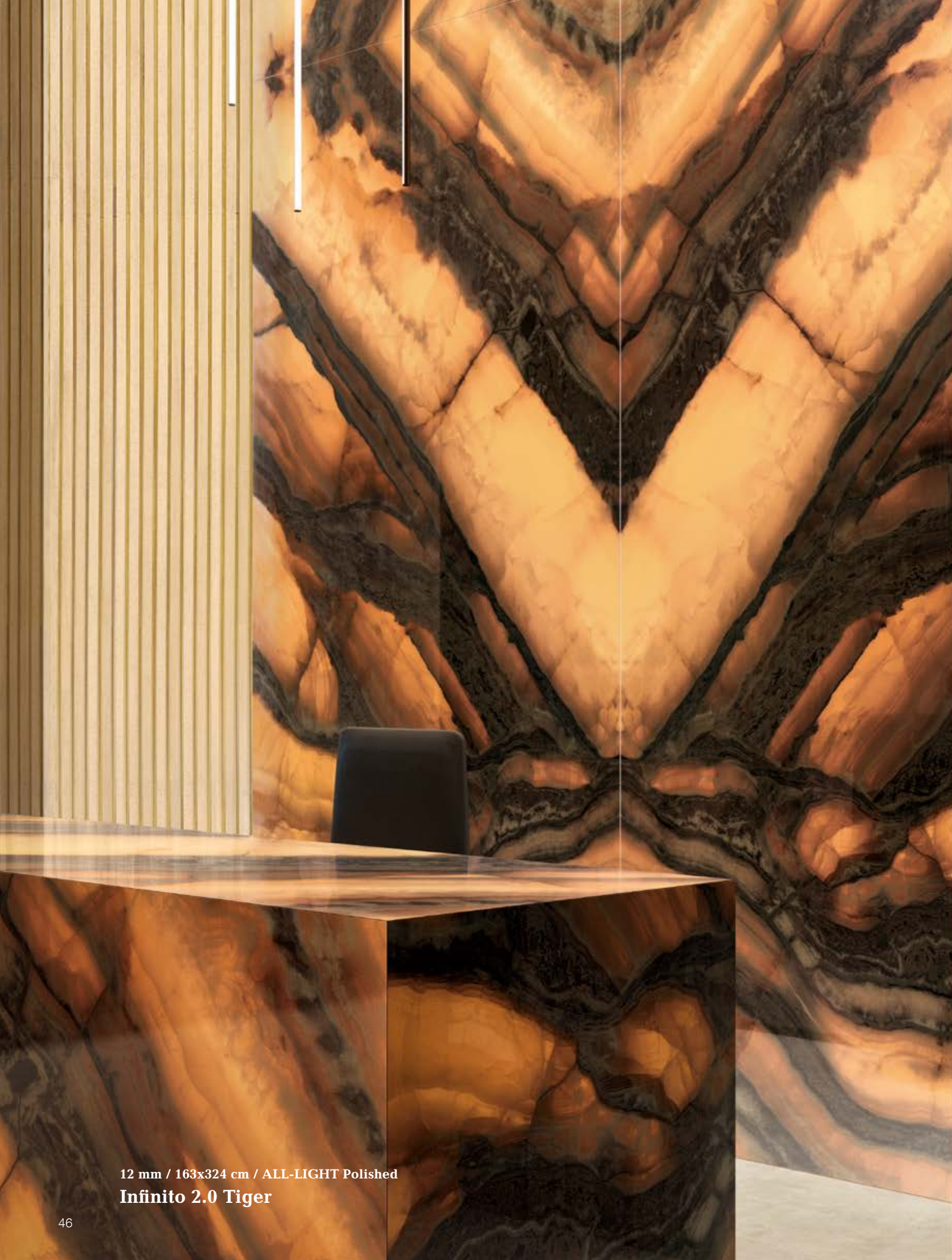

## Infinito 2.0 Tiger

**Venature marcate e colori caldi, creano un pattern che emana luce di grande impatto estetico.**  
Bold veining and warm shades create a stunning pattern that radiates light.  
Des veines marquées et des couleurs chaudes créent un motif qui dégage une lumière d'un grand impact esthétique.  
Las vetas marcadas y los colores cálidos crean un patrón que irradia luz de gran impacto estético.  
Ausgeprägte Aderungen und warme Farben erzeugen ein Muster, das Licht von großer ästhetischer Wirkung ausstrahlt.

**12 mm  
163x324 cm**

**Available Finishes:  
ALL-LIGHT Polished**

12 mm / 163x324 cm / ALL-LIGHT Polished  
**Infinito 2.0 Tiger**



12 mm / 163x324 cm / ALL-LIGHT Polished  
**Infinito 2.0 Tiger**  
FLOOR Portland Jordan 120x120



## Infinito 2.0 Starlit

**Sfumature marmoree sui toni caldi  
che ricordano superfici retroilluminate.**

Marble-like shading in warm tones that  
create a seemingly backlit effect.

Des nuances de marbre dans des tons chauds  
qui rappellent les surfaces rétro-éclairées.

Matices marmolados en tonos cálidos  
que recuerdan superficies retroiluminadas.

Nuancen des Marmors in warmen Tönen,  
die an hinterleuchtete Oberflächen erinnern.

**12 mm  
163x324 cm**

**Available Finishes:  
ALL-LIGHT Polished**



12 mm / 163x324 cm / ALL-LIGHT Polished

**Infinito 2.0 Starlit**

FLOOR Pigmento Oro 120x120

## Infinito 2.0 Labradorite Royale

**Tonalità scure dal blu al grigio, con venature chiare che creano un contrasto tridimensionale.**  
Dark tones ranging from blue to grey, featuring pale veining that creates a textured contrast.  
Des nuances sombres du bleu au gris, et des veines claires qui créent un contraste tridimensionnel.  
Tonos oscuros que van del azul al gris, con vetas claras que crean un contraste tridimensional.  
Dunkle Farbtöne von Blau bis Grau, mit hellen Aderungen, die einen dreidimensionalen Kontrast erzeugen.

**12 mm  
163x324 cm**

**Available Finishes:  
ALL-LIGHT Polished**

12 mm / 163x324 cm / ALL-LIGHT Polished  
**Infinito 2.0 Labradorite Royale**



12 mm / 163x324 cm / ALL-LIGHT Polished  
**Infinito 2.0 Labradorite Royale**  
FLOOR Komi Elegant 40x240

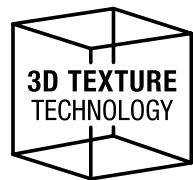

## Infinito 2.0 Calacatta Paris

**Un marmo chiaro su cui si intrecciano vene scure a contrasto, per delicati motivi a macchia.**

A pale marble featuring contrasting dark veins, intertwined to form a gently dappled effect.

Un marbre clair sur lequel s'entrelacent des veines sombres contrastées, formant de délicats motifs mouchetés.

Un mármol claro surcado por vetas en contraste, que se entrelazan formando delicados motivos moteados.

Ein heller Marmor, auf dem sich kontrastierende dunkle Adern verflechten, um zarte Fleckenmotive zu erzeugen.

**12 mm  
163x324 cm**

**Available Finishes:  
Full 3D Texture  
Polished**



12 mm / 163x324 cm / Full 3D Texture  
Infinito 2.0 Calacatta Paris



12 mm / 163x324 cm / Full 3D Texture  
**Infinito 2.0 Calacatta Paris**  
FLOOR Jura Nude Real Matt 120x120



## Infinito 2.0 Tiffany Green

**L'eleganza racchiusa tra le sfumature verdi di un marmo dalla texture decisa e potente.**  
The innate elegance of marble, expressed in shades of green with a striking texture.  
L'élégance enfermée dans les nuances vertes d'un marbre à la texture nette et puissante.  
La elegancia propia de los matices verdes de un mármol de textura decidida y potente.  
Die in den grünen Schattierungen eines Marmors mit einer markanten und kraftvollen Textur eingeschlossene Eleganz.

**12 mm  
163x324 cm**

**Available Finishes:  
Polished**

12 mm / 163x324 cm / Polished  
**Infinito 2.0 Tiffany Green**

FLOOR Royal Travertino Bianco 3D Texture Satin 120x120



## Infinito 2.0 Meteor

**Superfici eteree e cristalline vibrano alla luce.**  
Ethereal, shimmering crystalline surfaces.  
Des surfaces éthérées et cristallines vibrent à la lumière.  
Superficies etéreas y cristalinas que vibran con la luz.  
Ätherische, kristalline Oberflächen schimmern im Licht.

**12 mm  
163x324 cm**

**Available Finishes:  
Crystal Polished**

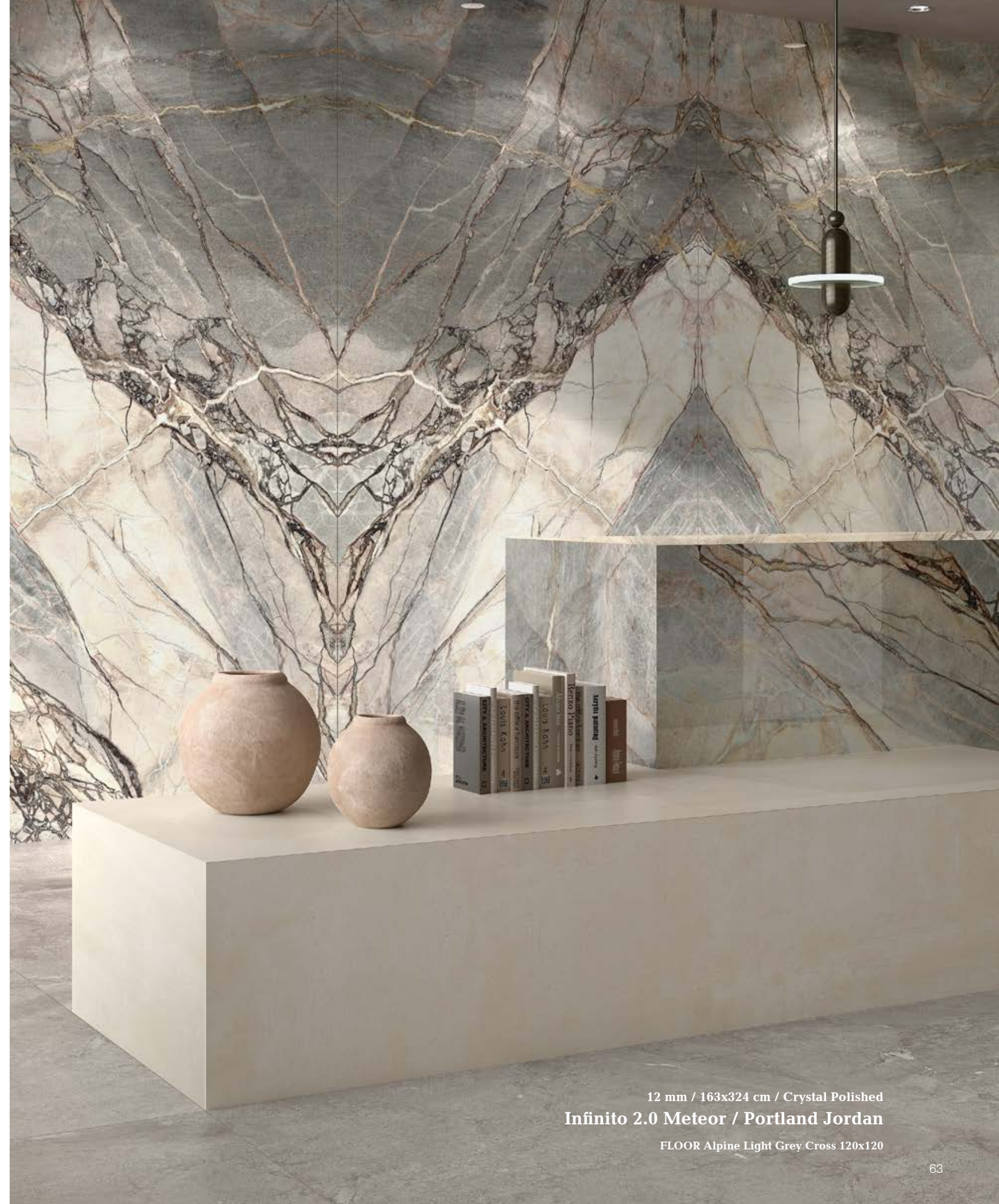

12 mm / 163x324 cm / Crystal Polished  
**Infinito 2.0 Meteor / Portland Jordan**

FLOOR Alpine Light Grey Cross 120x120



12 mm / 163x324 cm / Crystal Polished  
**Infito 2.0 Meteor / Portland Jordan**  
FLOOR Alpine Light Grey Cross 120x120

## Infinito 2.0 Thassos

**Superfici bianco candido arricchite da particelle di cristalli e pigmenti perlescenti.**  
Pure white surfaces enhanced with crystalline flecks and pearly pigments.  
Des surfaces blanc pâle enrichies de particules de cristaux et de pigments nacrés.  
Superficies de un blanco puro enriquecidas con partículas de cristales y pigmentos nacarados  
Reinweiße Oberflächen, angereichert mit Kristallpartikeln und Perlglanzpigmenten.

**12 mm  
163x324 cm**

**Available Finishes:  
Crystal Polished**

12 mm / 163x324 cm / Crystal Polished

**Infinito 2.0 Thassos**

WALL Dream Fresco 60x120  
FLOOR Res Art Ash 120x120

# Infinito 2.0 Statuarietto/Black Pearl

**Sottili venature che si diramano eleganti su sfondi candidi e scuri.**  
Thin veins extend elegantly over bright white and dark backgrounds.  
Des veines fines qui se ramifient élégamment sur des fonds blancs et sombres.  
Sutiles veteados que se ramifican con elegancia sobre fondos blancos y oscuros.  
Dünne Aderungen, die sich elegant auf hellem und dunklem Hintergrund verzweigen.



12 mm / 163x324 cm / Natural  
**Infinito 2.0 Statuarietto**  
WALL Alpine Pine Vein 120x278

**12 mm**  
**163x324 cm**

**Available Finishes:**  
**Natural**



12 mm / 163x324 cm / Natural  
**Infinito 2.0 Black Pearl**  
FLOOR Komi Original 24x240

# Infinito 2.0 Calacatta Macchia Vecchia

**Accenti di colore beige e bruno si trasformano in sofisticate trame.**  
Hints of beige and brown morph into stylish textures.  
Des accents beiges et bruns se transforment en trames sophistiquées.  
Acentos de color beige y marrón que se transforman en sofisticadas texturas.  
Beige und braune Farbakzente verwandeln sich in raffinierte Texturen.

**12 mm  
163x324 cm**

**Available Finishes:  
Polished**



**12 mm / 163x324 cm / Polished  
Infinito 2.0 Calacatta Macchia Vecchia**

FLOOR Homescape Sugar 120x120  
WALL Homescape Sugar Tub 60x120

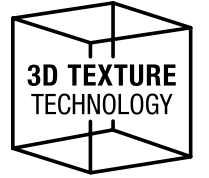

## Infinito 2.0 Cream Diamonds

**Profondità estetica senza precedenti, dal fascino morbido e avvolgente.**  
Unparalleled visual depth and a gentle, captivating beauty.  
Une profondeur esthétique sans précédent, au charme doux et enveloppant.  
Profundidad estética sin precedentes con un atractivo suave y envolvente.  
Eine völlig neue ästhetische Tiefe, mit einem weichen und umhüllenden Charme.

**12 mm  
163x324 cm**

**Available Finishes:  
Full 3D Texture Polished  
Full 3D Texture**

12 mm / 163x324 cm / Full 3D Texture  
**Infinito 2.0 Cream Diamonds**

FLOOR Komi Natural 24x240



12 mm / 163x324 cm / Full 3D Texture  
**Infinito 2.0 Cream Diamonds**  
FLOOR Komi Natural 24x240



**Furniture SHAPE**

OMIK 270x110 / OMIK COFFEE 117x56\_barrel top:  
Infinito 2.0 Cream Diamonds Full 3D Texture Polished +  
All-Over / Ottone Spazzolato

FLOOR Homescape Sugar 120x120

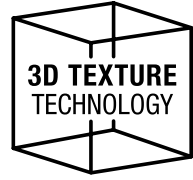

## Infinito 2.0 Cliff White

**Venature decise e vibranti dal forte impatto cromatico.**  
Bold, vibrant veining with a striking colour impact.  
Des veines prononcées et vibrantes avec un fort impact chromatique.  
Vetas fuertes y vibrantes con un fuerte impacto cromático.  
Starke und lebendige Aderungen mit starker chromatischer Wirkung.

**12 mm  
163x324 cm**

**Available Finishes:  
Full 3D Texture**



12 mm / 163x324 cm / Full 3D Texture  
Infinito 2.0 Cliff White



12 mm / 163x324 cm / Full 3D Texture  
**Infinito 2.0 Cliff White**

FLOOR Homescape Sugar 120x120  
WALL Homescape Sugar Tub 60x120

12 mm / 163x324 cm / Polished  
Infinito 2.0 Golden Spider



## Infinito 2.0 Golden Spider

**Luminosità unica su fondo bianco con sottili venature rosate.**

Unique brightness radiating from pink gossamer-like veining against a white background.  
Une luminosité unique sur fond blanc avec de fines veines roses.  
Luminosidad única sobre fondo blanco con finas vetas rosadas.  
Einzigartige Helligkeit auf weißem Untergrund mit dünnen rosafarbenen Aderungen.

**12 mm**  
**163x324 cm**

**Available Finishes:**  
**Polished**



12 mm / 163x324 cm / Polished  
**Infinito 2.0 Golden Spider**  
FLOOR Komi Elegant 24x240

# Infinito 2.0 Luxury Gold

**Nuance dorate con striature a contrasto.**  
Golden shades with contrasting streaks.  
Des nuances dorées avec des stries contrastées.  
Matices dorados con rayas en contraste.  
Goldene Nuancen mit kontrastierenden Streifen.

**12 mm**  
**163x324 cm**

**Available Finishes:**  
**Polished**



12 mm / 163x324 cm / Polished  
**Infinito 2.0 Luxury Gold**  
FLOOR Komi Natural 24x240



12 mm / 163x324 cm / Polished  
Infinito 2.0 Luxury Gold

# Infinito 2.0 Breccia Van Gogh

**Estetica sofisticata, colori neutri tra ocre e terre.**

A sophisticated aesthetic featuring neutral colours in ochre and earthy tones.  
Une esthétique sophistiquée, des couleurs neutres entre ocres et terres.  
Estética sofisticada, colores neutros entre ocre y tierras.  
Raffinierte Ästhetik, neutrale Farben zwischen Ocker und Erde.

**12 mm  
163x324 cm**

**Available Finishes:  
Polished**



12 mm / 163x324 cm / Polished  
**Infinito 2.0 Breccia Van Gogh**



12 mm / 163x324 cm / Polished  
**Infinito 2.0 Breccia Van Gogh**  
FLOOR Homescape Caramel 120x120

# Infinito 2.0 Taj Mahal

**Venature e nuvolature sfumano in un elegante unicum senza tempo.**  
Veining and clouding merge within this unique option with timeless elegance.  
Les veines et les taches s'estompent dans un unicum élégant et intemporel.  
Las vetas y las nubes se difuminan en un elegante unicum atemporal.  
Aderungen und Wolken verschmelzen zu einem eleganten, zeitlosen Unikat.

**12 mm  
163x324 cm**

**Available Finishes:  
Polished**



**12 mm / 163x324 cm / Polished  
Infinito 2.0 Taj Mahal**



## Infinito 2.0 Patagonia

**La pregiata naturalezza di un marmo ricercato.**  
The natural prestige of a sophisticated marble.  
Le naturel précieux d'un marbre raffiné.  
La preciada naturalidad de un mármol refinado.  
Die kostbare Natürlichkeit eines edlen Marmors.

**12 mm**  
**163x324 cm**

**Available Finishes:**  
**Polished**  
**Natural**

12 mm / 163x324 cm / Polished  
**Infinito 2.0 Patagonia**

# Infinito 2.0 Fior Di Bosco

**Superficie calda, ispirata a un marmo italiano con venature preziose.**

An inviting material inspired by an Italian marble with exquisite veining.

Une surface chaude, inspirée d'un marbre italien avec des veines précieuses.

Superficie cálida, inspirada en un mármol italiano con vetas preciosas.

Warme Oberfläche, inspiriert von einem italienischen Marmor mit kostbaren Aderungen.

**12 mm  
163x324 cm**

**Available Finishes:  
Polished  
Honed**



12 mm / 163x324 cm / Polished  
Infinito 2.0 Fior di Bosco



12 mm / 163x324 cm / Polished  
**Infinito 2.0 Fior Di Bosco**



# Infinito 2.0 Royal Creamy

**Venature chiare su un fondo caldo e leggermente mosso, dal contrasto elegante e raffinato.**  
Pale veining set against an inviting, softly undulating background creates a stylish, elegant contrast.  
Des veines claires sur un fond chaud et légèrement ondulé, au contraste élégant et raffiné.  
Vetas claras sobre un fondo cálido y ligeramente ondulado, con contraste elegante y refinado.  
Helle Aderungen auf einem warmen und leicht bewegten Hintergrund, mit einem eleganten und raffinierten Kontrast.

**12 mm  
163x324 cm**

**Available Finishes:  
Natural**

12 mm / 163x324 cm / Natural  
**Infinito 2.0 Royal Creamy**  
FLOOR Dream Snow 120x278  
WALL Dream Camellia 120x278

# Infinito 2.0 Gold River

**Vene dal bronzo al bordeaux creano una trama ricca e profonda, con riflessi brillanti.**  
Veining ranging from bronze to burgundy in tone creates a rich texture with glimmering reflections.  
Des veines allant du bronze au bordeaux créent une trame riche et profonde, avec des reflets brillants.  
Vetas que van del bronze al burdeos crean una trama rica y profunda, con reflejos brillantes.  
Adern von Bronze bis Burgunderrot erzeugen eine reichhaltige und tiefe Textur mit brillanten Reflexen.

**12 mm  
163x324 cm**

**Available Finishes:  
Polished**



12 mm / 163x324 cm / Polished  
**Infinito 2.0 Gold River**

WALL Brit Tobacco 6x24,6



**Furniture SHAPE**

BLUNT 300x117\_Infinito 2.0 Gold River Polished + All-Over / Pachuca

FLOOR Homescape Caramel 120x120





12 mm / 163x324 cm / Polished  
**Infinito 2.0 Rosso Lepanto**

FLOOR Portland Hood 120x120  
WALL Res Art Pottery Mosaico Ball 30x30

## Infinito 2.0 Rosso Lepanto

**Eleganza classica e giochi visivi in continuo mutamento.**  
Classic elegance and constantly changing visual effects.  
Une élégance classique et des jeux visuels sans cesse renouvelés.  
Elegancia clásica y juegos visuales de cambio continuo.  
Klassische Eleganz und sich ständig verändernde visuelle Spiele.

12 mm  
163x324 cm

Available Finishes:  
**Polished**

# Infinito 2.0 Calacatta Viola

**Venature violacee accentuate dalla lucentezza della superficie polished.**  
Purple veining accentuated by a glossy polished surface.  
Des veines violettes accentuées par la brillance de la surface polished.  
Vetas violáceas acentuadas por el brillo de la superficie pulida.  
Violette Aderungen, die durch den Glanz der polierten Oberfläche akzentuiert werden.

**12 mm  
163x324 cm**

**Available Finishes:  
Natural  
Polished**



12 mm / 163x324 cm / Polished  
**Infinito 2.0 Calacatta Viola**  
WALL Komi Elegant Lodge 120x278

< Lounge  
< Terrace  
< Spa

12 mm / 163x324 cm / Polished  
**Infinito 2.0 Calacatta Viola**

FLOOR Pigmento Carbone 120x120  
WALL Komi Elegant Lodge 120x278



## Infinito 2.0 Capraia

**Effetto marmo bianco con striature grigie, viola e verde, dalla ricca versatilità decorativa.**  
 White marble effect featuring grey, purple, and green streaks and offering great decorative versatility.  
 L'effet marbre blanc avec des stries grises, violettes et vertes, avec une riche polyvalence décorative.  
 Efecto mármol blanco con vetas grises, morado y verde, con una rica versatilidad decorativa.  
 Weißer Marmor-Effekt mit grauen, violetten und grünen Streifen, mit reicher dekorativer Vielseitigkeit.

**12 mm  
163x324 cm**

**Available Finishes:  
Polished  
Honed  
Natural**



**12 mm / 163x324 cm / Polished  
Infinito 2.0 Capraia  
FLOOR Komi Natural 40x240**

# Infinito 2.0 Calacatta Light

**Striature grigie su bianco creano un volume scultoreo d'impatto.**  
Grey streaks against a white background form a striking sculptural presence.  
Des stries grises sur fond blanc créent un volume sculptural impressionnant.  
Las vetas grises sobre fondo blanco crean un volumen escultural de gran impacto.  
Graue Streifen auf Weiß erzeugen ein wirkungsvolles skulpturales Volumen.

**12/20 mm  
163x324 cm**

**Available Finishes:  
Polished  
Honed  
Natural**



**12 mm / 163x324 cm / Polished  
Infinito 2.0 Calacatta Light**



12 mm / 163x324 cm / Polished  
**Infinito 2.0 Calacatta Light**  
FLOOR Slaten Stone Sand 120x120



12 mm / 163x324 cm / Natural  
**Infinito 2.0 Calacatta Venice**

FLOOR Jura Mood Natural 3D Texture Satin 120x120

## **Infinito 2.0 Calacatta Venice**

**Toni caldi delicati per ambienti  
eleganti e accoglienti.**

Subtle, warm tones for stylish,  
welcoming spaces.

Des tons chauds délicats pour des  
espaces élégants et accueillants.

Tonos delicados y cálidos para  
ambientes elegantes y acogedores.

Warme, sanfte Farben für elegante  
und einladende Räume.

**12 mm  
163x324 cm**

**Available Finishes:**

**Natural  
Polished**

# Infinito 2.0 Calacatta White

**Un'icona di raffinatezza dalla bellezza cristallina ed eleganti venature.**  
A symbol of sophistication, featuring crystalline allure and elegant veining.  
Une icône de raffinement à la beauté cristalline et aux veines élégantes.  
Un icono de refinamiento con una belleza cristalina y vetas elegantes.  
Eine Ikone der Raffinesse mit kristalliner Schönheit und eleganten Aderungen.



**12 mm  
163x324 cm**

**Available Finishes:  
Polished  
Honed**



12 mm / 163x324 cm / Honed  
**Infinito 2.0 Calacatta White**



12 mm / 163x324 cm / Honed  
**Infinito 2.0 Calacatta White**



12 mm / 163x324 cm / Polished  
**Infinito 2.0 Statuario Extra**  
FLOOR Homescape Coal 120x120

## Infinito 2.0 Statuario Extra

**Una superficie luminosa e versatile offre bellezza e funzionalità per il mondo dell'arredo.**

A radiant, versatile surface offering beauty and functionality for the world of furnishings.  
Une surface lumineuse et polyvalente offre beauté et fonctionnalité pour le monde de la décoration.  
Una superficie luminosa y versátil ofrece belleza y funcionalidad al mundo del mueble.  
Eine helle und vielseitige Oberfläche bietet Schönheit und Funktionalität für die Welt der Einrichtung.

**12/20 mm  
163x324 cm**

**Available Finishes:  
Polished  
Honed  
Natural**



12 mm / 163x324 cm / Polished  
**Infinito 2.0 Statuario Extra**

# Infinito 2.0 Elegant White

**Leggerezza e luminosità, con delicati movimenti neutri su fondo bianco.**  
Lightness, brightness, and subtle neutral patterns against a white background.  
Légèreté et luminosité, avec de délicats mouvements neutres sur fond blanc.  
Ligereza y luminosidad, con delicados movimientos neutros sobre fondo blanco.  
Leichtigkeit und Leuchtkraft, mit zarten neutralen Bewegungen auf weißem Hintergrund.

**12 mm  
163x324 cm**

**Available Finishes:  
Natural**



12 mm / 163x324 cm / Natural  
**Infinito 2.0 Elegant White**

FLOOR Background Cloud 120x120  
WALL Background Cloud 120x278 / Cloud Line 60x120

# Infinito 2.0 Super White

**Nuovi equilibri di forme raccontano nel dettaglio la purezza del bianco.**  
Forms in fresh equilibrium detail the purity of white.  
De nouveaux équilibres de formes racontent en détail la pureté du blanc.  
Nuevos equilibrios de formas que relatan en detalle la pureza del blanco.  
Die reine Ausstrahlung von Weiß in neuen Formenbalancen.

**12 mm  
163x324 cm**

**Available Finishes:  
Natural  
Polished**



**12 mm / 163x324 cm / Polished  
Infinito 2.0 Super White**

FLOOR Komi Elegant 40x240  
WALL Infinito 2.0 Super White 120x278 / Res Art Cameo 120x278



## Infinito 2.0 Calacatta Gold

**Fondo bianco latte con sfumature grigie e striature dorate che brillano alla luce.**  
A milky white background featuring shades of greige set off by resplendent streaks of gold.  
Fond blanc laiteux avec des nuances grèges et des stries dorées qui étincellent à la lumière.  
Fondo blanco leche con tonos grisáceos y vetas doradas que brillan con la luz.  
Milchig-weißer Hintergrund mit beige-grauen Tönen und goldenen Streifen, die im Licht funkeln.

**12/20 mm  
163x324 cm**

**Available Finishes:  
Polished  
Honed  
Natural**



12 mm / 163x324 cm / Polished  
**Infinito 2.0 Calacatta Gold**

## Infinito 2.0 Green Denis

**Il mosaico di verdi con accenti chiari è esaltato dalla superficie lucida.**

A mosaic of greens enhanced with pale accents, set off by a glossy surface.

La mosaïque de verts aux accents clairs est rehaussée par la surface brillante.

El mosaico de verdes con acentos claros se ve realizado por la superficie brillante.

Das Mosaik aus Grüntönen mit hellen Akzenten wird durch die glänzende Oberfläche hervorgehoben.

**12 mm  
163x324 cm**

**Available Finishes:  
Polished**



**12 mm / 163x324 cm / Polished  
Infinito 2.0 Green Denis**

**FLOOR Background Snowy 60x120  
WALL Background Snowy 120x278 / Snowy Line 60x120**



**Furniture SHAPE**

SIDE SQUARE 160x160\_Infinito 2.0 Green Denis Polished + Aile d'avion / Nero  
SMART BLOCK 71,7x46x102,3H Smoked Mirror / 71,7x46x102,3H - 36,7x46x102,3H Gres\_Infinito 2.0 Green Denis Polished + All Over  
FLOOR Background Cloud 120x120





## Infinito 2.0 Calacatta Green

**Grafica in avorio, greige e verde con movimenti delicati e nuvolature leggere.**

Ivory, greige, and green patterns featuring delicate flowing and cloudlike forms.

Un graphisme ivoire, grège et vert avec des mouvements délicats et des nuages légers.

Gráficos en marfil, gris/beige y verde con movimientos delicados y ligeras nubes.

Elfenbeinfarbene, beige-graue und grüne Grafiken mit sanften Bewegungen und leichten Wolken.

**12 mm  
163x324 cm**

**Available Finishes:  
Polished**

12 mm / 163x324 cm / Polished  
**Infinito 2.0 Calacatta Green**

FLOOR Komi Elegant 40x240

## Infinito 2.0 River Jade

**Estetica ricca con striature oblique in toni di verde, grigio, beige e nero**  
A lavish aesthetic featuring slanted streaks of green, grey, beige, and black.  
Une esthétique riche avec des stries obliques dans les tons vert, gris, beige et noir.  
Estética rica con estrías oblicuas en tonos de verde, gris, beige y negro.  
Reiche Ästhetik mit schrägen Streifen in Grün-, Grau-, Beige- und Schwarztönen.

**12 mm**  
**163x324 cm**

**Available Finishes:**  
**Polished**



12 mm / 163x324 cm / Polished  
Infinito 2.0 River Jade



12 mm / 163x324 cm / Polished  
**Infinito 2.0 River Jade**

FLOOR Res Art Ash 120x120

# Infinito 2.0 Amazzonite

**Estetica intensa con toni di verde, azzurro e smeraldo, arricchita da vene e inserti oro e bronzo.**  
A intense aesthetic featuring green, pale blue, and emerald tones, enhanced with gold and bronze veining and inserts.  
Une esthétique intense avec des tons vert, bleu et émeraude, enrichie de veines et d'incrustations or et bronze.  
Estética intensa con tonos verdes, azules y esmeralda, enriquecida con vetas e inserciones doradas y bronce.  
Intensive Ästhetik mit Grün-, Blau- und Smaragdtönen, angereichert mit Gold- und Bronzeadern und -einsätzen.

**12 mm  
163x324 cm**

**Available Finishes:  
Polished**

**12 mm / 163x324 cm / Polished  
Infinito 2.0 Amazzonite**

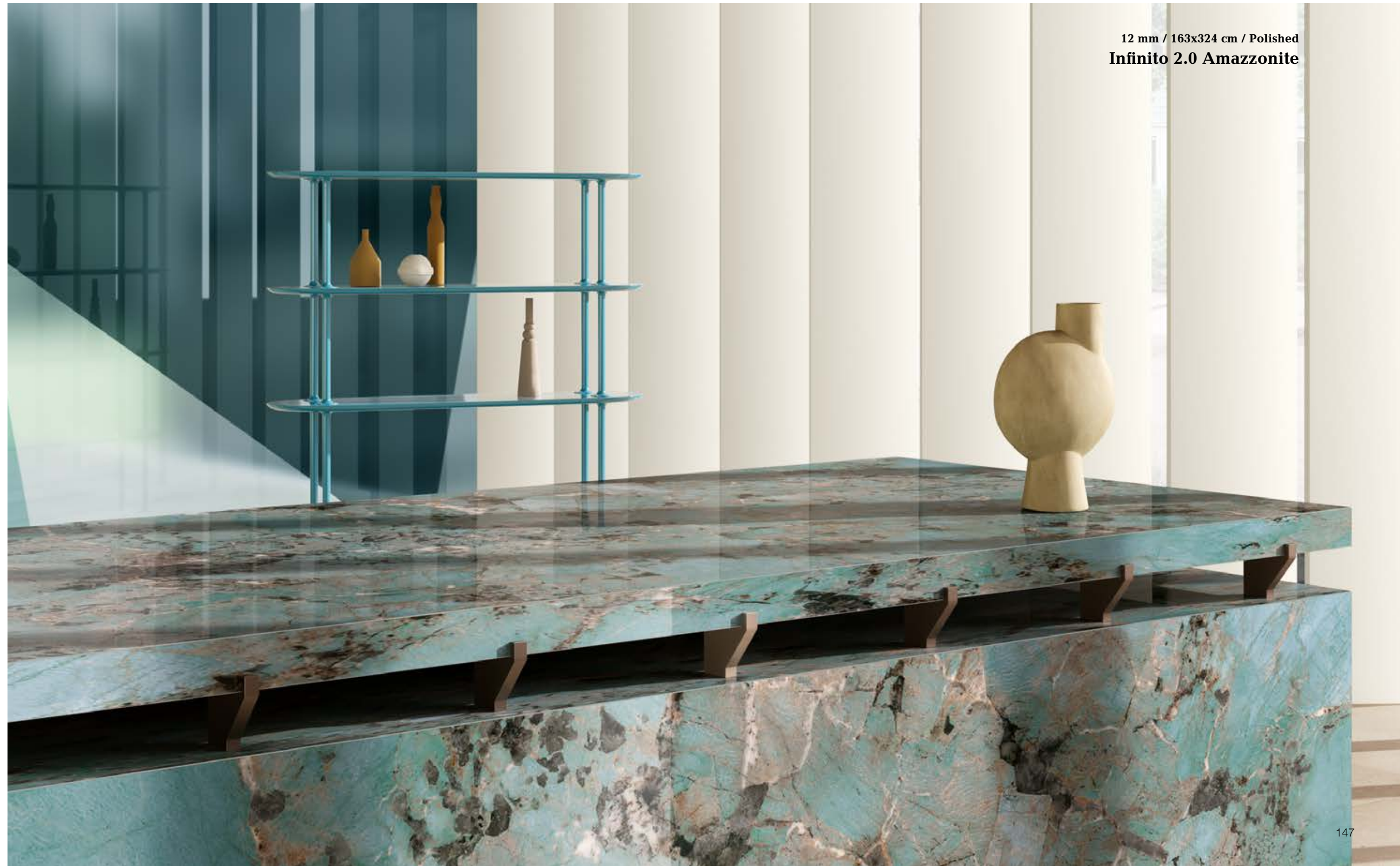



**Furniture SHAPE**

RAKI 300x110\_barrel top:  
Infinito 2.0 Amazonite Polished + All-Over / Nero

FLOOR Komi Natural 40x240

12 mm / 163x324 cm / Honed  
**Infinito 2.0 Blue Roma**  
WALL Brit Ocean 6x24,6



## Infinito 2.0 Blue Roma

**Design elegante con celesti raffaelliani, venature beige e bianche simili a pennellate di Constable.**

An elegant design featuring the sky blues favoured by Raphael and beige and white veining reminiscent of the brush strokes of Constable.

Un design élégant avec des bleu ciel raphaéliens, des veines beige et blanches semblables aux coups de pinceau de Constable.

Diseño elegante con celestes rafaelianos, vetas beige y blancas similares a las pinceladas de Constable.

Elegantes Design mit raffaelblauen, beigen und weißen Aderungen, die an die Pinselstriche von Constable erinnern.

**12 mm**  
**163x324 cm**

**Available Finishes:**  
**Polished**  
**Honed**



12 mm / 163x324 cm / Honed  
**Infinito 2.0 Blue Roma**

FLOOR Komi Natural 24x240  
WALL Brit Almond 6x24,6



12 mm / 163x324 cm / Polished  
**Infinito 2.0 Emerald Green**  
FLOOR Pigmento Fango 120x120

## Infinito 2.0 Emerald Green

**Sfondo verde brillante sfumato crea un insieme armonioso e naturale.**  
This bright green background tile features shading that creates a harmonious, natural mood.  
Le fond vert brillant nuancé crée un ensemble harmonieux et naturel.  
El fondo verde brillante difuminado crea un conjunto armonioso y natural.  
Der hellgrüne Untergrund mit Farbverlauf schafft ein harmonisches und natürliches Ganzes.

**12 mm**  
**163x324 cm**

**Available Finishes:**  
**Polished**





## Infinito 2.0 Agate Crystal Jade

Con i suoi verdi profondi e accenti dorati e bronzati,  
**Agate Crystal Jade emana design affascinante.**  
With its deep greens and gold and bronze accents,  
Agate Crystal Jade exudes high-end allure.  
Avec ses verts profonds et ses accents or et bronze,  
Agate Crystal Jade dégage un design fascinant.  
Con sus verdes profundos y sus acentos dorados y bronceados,  
Agate Crystal Jade irradia un diseño fascinante.  
Mit seinen tiefen Grüntönen und goldenen und bronzefarbenen  
Akzenten, weist Achat Crystal Jade ein reizvolles Design auf.

**12 mm**  
**163x324 cm**

**Available Finishes:**  
**Polished**

12 mm / 163x324 cm / Polished  
**Infinito 2.0 Agate Crystal Jade**

FLOOR Homescape Sugar 120x120



12 mm / 163x324 cm / Polished  
**Infinito 2.0 Agate Crystal Jade**  
FLOOR Homescape Sugar 120x120



## Infinito 2.0 Agate Crystal Lace

**Pietra iconica dal fondo mosso che esprime la ricchezza del materiale con stratificazioni e inclusioni calde.**

An iconic stone material featuring a gently undulating background that brings out its richness, enhanced by warm-toned layers and inserts.

Pierre iconique au fond mouvant qui exprime la richesse du matériau avec des stratifications et des inclusions chaudes.

Piedra icónica con fondo ondulado que expresa la riqueza del material con estratificaciones e inclusiones cálidas.

Ikonscher Stein mit einem wellenförmigen Untergrund, der den Reichtum des Materials durch Schichten und warme Einschlüsse zum Ausdruck bringt.

**12 mm  
163x324 cm**

**Available Finishes:  
Polished**



12 mm / 163x324 cm / Polished  
**Infinito 2.0 Agate Crystal Lace**

FLOOR Komi Original 24x120



## Infinito 2.0 Agate Blue Velvet

**I toni azzurri, celesti e grigi, con superficie lucida, creano un'estetica luminosa e coraggiosa.**  
Cerulean blue, sky blue, and grey tones with a high-gloss surface create a bold, bright aesthetic.  
Les tons bleu ciel et gris, avec une surface brillante, créent une esthétique lumineuse et courageuse.  
Los tonos azules, celestes y grises, con una superficie brillante, crean una estética luminosa y audaz.  
Die blauen, hellblauen und grauen Töne mit glänzender Oberfläche schaffen eine helle und mutige Ästhetik.

**12 mm  
163x324 cm**

**Available Finishes:  
Polished**

12 mm / 163x324 cm / Polished  
**Infinito 2.0 Agate Blue Velvet**

FLOOR Pigmento Oro 120x120



12 mm / 163x324 cm / Polished  
**Infinito 2.0 Agate Blue Velvet**  
FLOOR Pigmento Oro 120x120

# Infinito 2.0 Port Laurent

**Sfondo nero e marrone, dettagli dorati e filamenti bianchi, esprimono il fascino della natura.**

This black and brown background tile, featuring golden details and white streaks, embodies the beauty of nature.

Un fond noir et marron, des détails dorés et des filaments blancs, expriment le charme de la nature.

El fondo negro y marrón, los detalles dorados y los filamentos blancos expresan el encanto de la naturaleza.

Schwarzer und brauner Untergrund, goldene Details und weiße Fäden bringen den Charme der Natur zum Ausdruck

**12 mm  
163x324 cm**

**Available Finishes:  
Polished**



12 mm / 163x324 cm / Polished  
Infinito 2.0 Port Laurent



**Furniture: Shape**

NEW YORK 240x100 \_barrel top:  
Infinito 2.0 Port Laurent Polished + All-Over / Nero opaco

FLOOR Royal Travertino Ebur Cross Real Matt 120x120



# Infinito 2.0 Pietra Grey

**Stratificazioni grigio-antracite e grigio-tortora con dettagli bianchi, per un aspetto pacato e versatile.**  
Anthracite grey and dove grey layers with white details, for a versatile materials that exudes calmness.  
Des stratifications gris anthracite et gris tourterelle avec des détails blancs, pour un aspect paisible et polyvalent.  
Capas gris antracita y gris tórtola con detalles en blanco, para un look tranquilo y versátil.  
Anthrazit-graue und taubengraue Schichtenbildungen mit weißen Details für einen weichen, vielseitigen Look.

**12 mm  
163x324 cm**

**Available Finishes:  
Polished  
Natural**

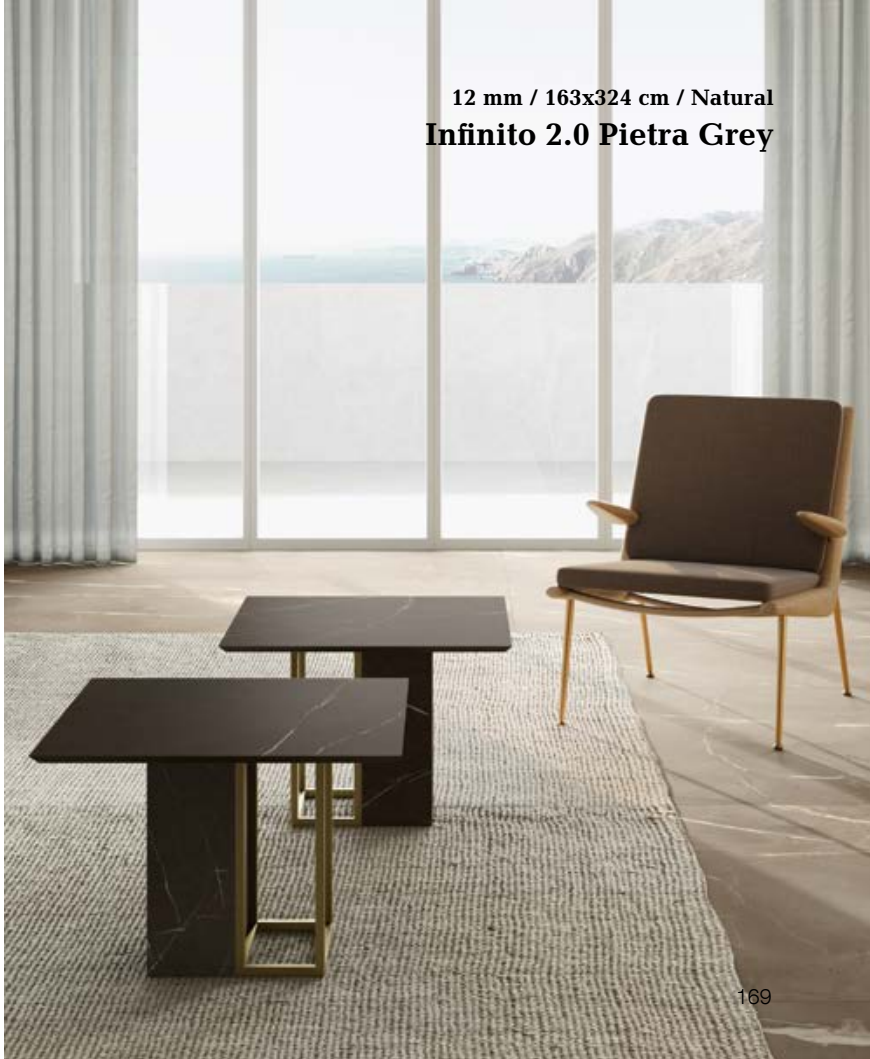

**12 mm / 163x324 cm / Natural  
Infinito 2.0 Pietra Grey**

**12 mm / 163x324 cm / Polished  
Infinito 2.0 Pietra Grey**

## Infinito 2.0 Sahara Noir

Una superficie "total black" è attraversata da linee bianche con sfumature arancio e marrone.  
A "total black" surface featuring white striations tinged with hints of orange and brown.  
Une surface « total black » est traversée par des lignes blanches avec des nuances orange et marron.  
Una superficie «total black» está atravesada por líneas blancas con matices naranja y marrón.  
Eine Fläche "total black" wird von weißen Linien mit Orange- und Brauntönen durchzogen.

12 mm  
163x324 cm

Available Finishes:  
Polished  
Honed



12 mm / 163x324 cm / Polished  
Infinito 2.0 Sahara Noir

---

## INSPIRATIONS: DIFFERENT SURFACES

ISPIRAZIONI: ALTRE SUPERFICI

Una pregiata selezione di varie ispirazioni materiche: la pietra, con la sua intrinseca naturalezza che si declina in cromie che spaziano dalle calde nuances terrose ai toni più freddi e raffinati; il legno, emblema di armonia eterna ed eleganza innata, capace di evocare avvolgenti sensazioni di calore, comfort e accoglienza; e il cemento, espressione di una sobria raffinatezza, incarnazione di una contemporaneità ricercata. Ciascuna di queste ispirazioni rievoca e reinterpreta le texture della natura, emulandone le preziose peculiarità.

A selection of offerings inspired by a variety of materials. Effects include: stone, with its intrinsic naturalness, in colour options ranging from warm earthy tones to cooler chic shades; wood, the essence of eternal harmony and innate elegance that infuses rooms with a cosy warmth; and concrete, the stylishly understated embodiment of sophisticated contemporary tastes. Each of these different effects conjures up the textures of nature, recreating their unique distinguishing features.

Une sélection raffinée de diverses inspirations matiéristes : la pierre, avec son naturel intrinsèque qui se décline dans des couleurs allant de nuances terreuses chaudes à des tons plus froids et raffinés ; le bois, emblème d'harmonie éternelle et d'élégance innée, capable d'évoquer des sensations enveloppantes de chaleur, de confort et de convivialité ; et le béton, expression d'un raffinement sobre, incarnation d'une contemporanéité raffinée. Chacune de ces inspirations évoque et réinterprète les textures de la nature, en imitant les précieuses particularités.

Eine edle Auswahl verschiedener Materialinspirationen: Stein mit seiner ihm innewohnenden Natürlichkeit, die in Farben von warmen erdigen Nuancen bis hin zu kälteren und raffinierteren Tönen zum Ausdruck kommt; Holz, ein Emblem ewiger Harmonie und angeborener Eleganz, das in der Lage ist, umhüllende Empfindungen von Wärme, Komfort und Gastfreundschaft hervorzurufen; und Beton, Ausdruck nüchternen Raffinesse, Verkörperung einer raffinierten Modernität. Jede dieser Inspirationen evoziert und interpretiert die Texturen der Natur neu und ahmt ihre kostbaren Eigenheiten nach.

**p.175**  
Stone Lab Sikelia

**p.178**  
Stone Lab Nebula Grey

**p.181**  
Stone Lab Nero Zimbabwe

**p.184**  
Stone Lab Negresco

**p.188**  
Stone Lab Colorado

**p.191**  
Stone Lab Travertino Bianco

**p.195**  
Stone Lab Travertino Ebur

**p.198**  
Stone Lab Travertino Fuscus

**p.201**  
Stone Lab Jura White

**p.202**  
Stone Lab Chianca

**p.205**  
Stone Lab Slate Black

**p.206**  
Stone Lab Silver Stone

**p.209**  
Stone Lab Ceppo

**p.210**  
Alpine Light Grey Vein

**p.213**  
Portland Hood

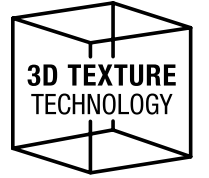

## Stone Lab Sikelia

**Ispirata alle pietre del sud Italia, dai delicati toni caldi.**  
Inspired by the stone materials of southern Italy, featuring subtle warm tones.  
Inspirée des pierres du sud de l'Italie, aux tons chauds et délicats.  
Inspirada en las piedras del sur de Italia, con delicados tonos cálidos.  
Inspiriert von den Steinen Südtaliens, mit zarten warmen Farbtönen.

**12 mm**  
**163x324 cm**

**Available Finishes:**  
**Full 3D Texture**

12 mm / 163x324 cm / Full 3D Texture  
Stone Lab Sikelia



12 mm / 163x324 cm / Full 3D Texture  
**Stone Lab Sikelia**

FLOOR Komi Classic 40x240

Furniture SHAPE BLUNT-EXT 180x90:  
Stone Lab Sikelia + All-Over / Pachuca

# Stone Lab Nebula Grey

**Venature intense e profonde dall'aspetto lavico e petroso.**  
Intense, deep veining for a distinctly rocky look reminiscent of lava.  
Des veines intenses et profondes à l'aspect lavique et pétrifié.  
Vetas intensas y profundas de aspecto magmático y pétreo.  
Intensive und tiefe Aderungen mit lavafarbenem und steinernem Aussehen.

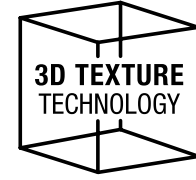

**12 mm**  
**163x324 cm**

**Available Finishes:**  
**Full 3D Texture**



12 mm / 163x324 cm / Full 3D Texture  
Stone Lab Nebula Grey



12 mm / 163x324 cm / Full 3D Texture  
Stone Lab Nebula Grey

FLOOR Homescape Coal 120x120

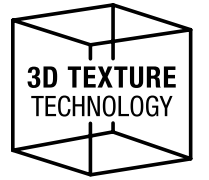

## Stone Lab Nero Zimbabwe

**Profondità grafica dall'intenso colore scuro.**  
Visual depth with rich, dark shades.  
Une profondeur graphique de couleur foncée intense.  
Profundidad gráfica de intenso color oscuro.  
Grafische Tiefe mit intensiver dunkler Farbe.

**12 mm**  
**163x324 cm**

**Available Finishes:**  
**Full 3D Texture**

12 mm / 163x324 cm / Full 3D Texture  
**Stone Lab Nero Zimbabwe**



12 mm / 163x324 cm / Full 3D Texture

**Stone Lab Zimbabwe**

FLOOR Alpine Silk Cross 120x120

WALL Dream Palace 120x278 / Alpine Silk Vein 120x278

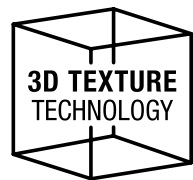

## Stone Lab Negresco

**Pietra naturale dalla struttura granulosa e dal fondo grigio.**  
Natural stone with a grainy texture and grey background.  
Pierre naturelle à la structure granuleuse et au fond gris.  
Piedra natural con textura granulada y fondo gris.  
Naturstein mit körniger Struktur und grauem Untergrund.

**12 mm  
163x324 cm**

**Available Finishes:  
3D Texture Real Matt**



12 mm / 163x324 cm / 3D Texture Real Matt  
Stone Lab Negresco



12 mm / 163x324 cm / 3D Texture / Real Matt  
**Stone Lab Negresco**  
FLOOR Komi Classic 24x240

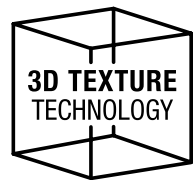

# Stone Lab Colorado

12 mm  
163x324 cm

**Piccole striature bianche su fondo beige dal morbido e piacevole effetto materico.**  
Small white streaks against a beige background create a gentle, pleasingly textured effect.  
De petites stries blanches sur fond beige à l'effet matiériste doux et agréable.  
Pequeñas vetas blancas sobre fondo beige con un suave y agradable efecto texturizado.  
Kleine weiße Streifen auf beigem Untergrund mit einem weichen und angenehmen Texturereffekt.

**Available Finishes:**  
3D Texture



12 mm / 163x324 cm / 3D Texture  
**Stone Lab Colorado**  
FLOOR Komi Natural 24x240

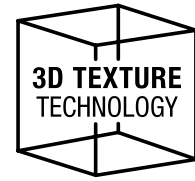

## Stone Lab Travertino Bianco

**La bellezza del bianco incontra il design contemporaneo.**  
The beauty of white meets contemporary design.  
La beauté du blanc rencontre le design contemporain.  
La belleza del blanco se une al diseño contemporáneo.  
Die Schönheit von Weiß im Dialog mit modernem Design.

**12 mm  
163x324 cm**

**Available Finishes:  
Full 3D Texture Honed  
Real Matt**

12 mm / 163x324 cm / Full 3D Texture Honed  
**Stone Lab Travertino Bianco**



12 mm / 163x324 cm / Full 3D Texture Honed  
**Stone Lab Travertino Bianco**

FLOOR Royal Travertino Bianco Cross 3D Texture Satin 120x120  
WALL Reflex Paltinum 120x278 / Reflex Platinum Chiffon 120x278

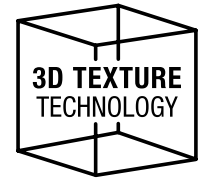

## Stone Lab Travertino Ebur

**Il fascino eterno della pietra simbolo di eleganza.**  
The eternal beauty of stone, symbol of elegance.  
Le charme éternel de la pierre symbole d'élégance.  
El encanto eterno de la piedra símbolo de elegancia.  
Der ewige Charme des Steins, ein Symbol der Eleganz.

**12 mm**  
**163x324 cm**

**Available Finishes:**  
**Full 3D Texture Honed**  
**Real Matt**

12 mm / 163x324 cm / Full 3D Texture Honed  
Stone Lab Travertino Ebur



12 mm / 163x324 cm / Real Matt  
**Stone Lab Travertino Ebur**  
FLOOR Komi Natural 24x240

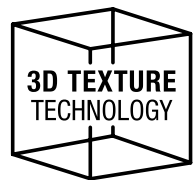

## Stone Lab Travertino Fuscus

**Protagonisti i toni bruni della terra.**  
Show-stealing shades of earthy brown.  
Les tons bruns de la terre en sont les protagonistes.  
Protagonistas los tonos marrones de la tierra.  
Protagonisten sind die brauen Farbtöne der Erde.

**12 mm  
163x324 cm**

**Available Finishes:  
Full 3D Texture Honed  
Real Matt**



12 mm / 163x324 cm / Real Matt  
**Stone Lab Travertino Fuscus**  
FLOOR Royal Travertino Navona Cross 120x120



## Stone Lab Jura White

**Tutti i dettagli delle pietre calcaree svizzere alpine.**  
All the detail of Swiss Alpine limestone.  
Tous les détails des pierres calcaires suisses alpines.  
Todos los detalles de las calizas alpinas suizas.  
Alle Details der Kalksteine aus den Schweizer Alpen.

**12 mm  
163x324 cm**

**Available Finishes:  
Real Matt**

12 mm / 163x324 cm / Real Matt  
**Stone Lab Jura White**  
FLOOR Homescape Clay 120x120

## Stone Lab Chianca

**Tonalità calde e neutre dalle atmosfere mediterranee.**  
Warm, neutral shades with a Mediterranean ambiance.  
Des tons chauds et neutres aux atmosphères méditerranéennes.  
Tonos cálidos y neutros de atmósferas mediterráneas.  
Warme und neutrale Töne mit mediterraner Atmosphäre.

**12 mm  
163x324 cm**

**Available Finishes:  
Real Matt**



12 mm / 163x324 cm / Real Matt  
**Stone Lab Chianca**  
FLOOR Portland Lassen 120x120



## Stone Lab Slate Black

**Sofisticate tonalità di nero e antracite, dall'estetica misteriosa.**  
Sophisticated shades of black and anthracite, with a mysterious aesthetic.  
Des nuances sophistiquées de noir et d'antracite, à l'esthétique mystérieuse.  
Sofisticados tonos de negro y antracita, con una estética misteriosa.  
Raffinierte Schwarz- und Anthrazittöne mit einer geheimnisvollen Ästhetik.

**12 mm  
163x324 cm**

**Available Finishes:  
Real Matt**

12 mm / 163x324 cm / Real Matt  
**Stone Lab Slate Black**  
FLOOR Background Cream 120x120

## Stone Lab Silver Stone

**Una superficie grigia raffinata, impreziosita da una texture.**  
A stylish grey option, enhanced with a textured surface.  
Une surface grise raffinée, enrichie d'une texture.  
Una superficie gris refinada, embellecida por una textura.  
Eine raffinierte graue Oberfläche, bereichert durch eine Textur.

**12 mm**  
**163x324 cm**

**Available Finishes:**  
**Natural**



12 mm / 163x324 cm / Natural  
**Stone Lab Silver Stone**

FLOOR Background Caviar 120x120  
WALL Background Caviar 120x278

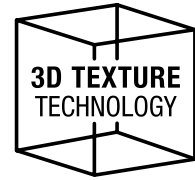

## Stone Lab Ceppo & Komi Elegant

**Un perfetto abbinamento tra effetto rovere e l'iconica pietra italiana del Ceppo di Grè.**

A perfect combination of oak effect and iconic Italian stone Ceppo di Grè.

Une combinaison parfaite entre l'effet chêne et la pierre italienne emblématique du Ceppo di Grè.

Una combinación perfecta de efecto roble y la emblemática piedra italiana de Ceppo di Grè.

Eine perfekte Kombination zwischen dem Eichen-Effekt und dem ikonischen italienischen Stein des Ceppo di Grè.

**12 mm  
163x324 cm**

**Stone Lab Ceppo Available Finishes:**

**Full 3D Texture**

**Real Matt**

**Komi Elegant Available Finishes:**

**Natural**

12 mm / 163x324 cm / Full 3D Texture  
**Stone Lab Ceppo**

12 mm / 163x324 cm / Natural  
**Komi Elegant**

FLOOR Komi Elegant 40x240

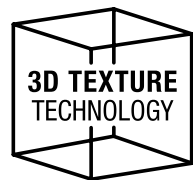

## Alpine Light Grey Vein

**Nuove sintonie tra superfici e stili di vita a ritmo lento.**  
New harmonies between surfaces and life lived at a slow pace.  
De nouvelles syntonies entre surfaces et  
styles de vie au rythme plus lent.  
Nuevas armonías entre superficies y estilos de vida pausados.  
Neue Harmonien zwischen ruhigen Flächenbildern  
und langsamen Lebensrhythmen.

**12 mm  
163x324 cm**

**Available Finishes:  
3D Texture**



12 mm / 163x324 cm / 3D Texture  
**Alpine Light Grey Vein**  
FLOOR Alpine Light Grey Cross 120x120



12 mm / 163x324 cm / Natural  
**Portland Hood**

## Portland Hood

**Design lineare che unisce estetica e funzionalità per arredi versatili.**  
A linear design that combines aesthetics and functionality for versatile creations.  
Design linéaire alliant esthétique et fonctionnalité pour des décors polyvalents.  
Diseño lineal que combina estética y funcionalidad para un mobiliario versátil.  
Geradliniges Design, das Ästhetik und Funktionalität für eine vielseitige Einrichtung vereint.

**12 mm  
163x324 cm**

**Available Finishes:  
Natural**



12 mm / 163x324 cm / Natural  
**Portland Hood**

---

## COLLECTIONS

COLLEZIONI

p.219  
Infinito 2.0

p.355  
Planeto

p.371  
Monochrome

p.345  
Stone Lab

p.361  
Portland

p.353  
Alpine

p.367  
Komi

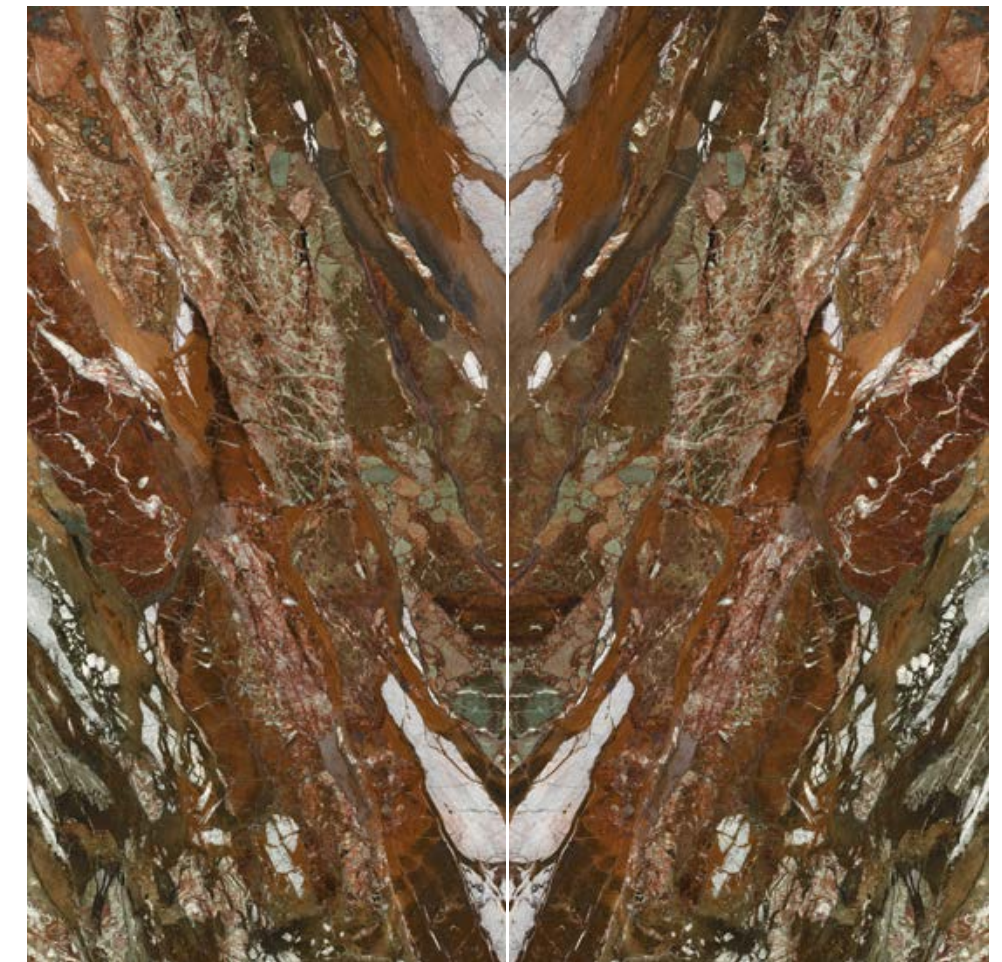

INF3671 Magnus *full 3D texture\_A*  
INF3662 Magnus *polished\_A*

INF3672 Magnus *full 3D texture\_B*  
INF3663 Magnus *polished\_B*

## 2 SURFACES

Full 3D Texture | Polished

L'effetto Bookmatch tra le diverse lastre è soggetto alla tolleranza tipica del prodotto lapideo.  
The bookmatching effect created by placing different slabs together is subject to the usual joint specifications of stone tiles. | L'effet Bookmatch entre différentes dalles est soumis à la tolérance typique du produit en pierre. | El efecto Bookmatch entre diferentes losas está sujeto a la tolerancia propia del producto pétreo. | Der Effekt des Bookmatching zwischen den verschiedenen Platten unterliegt der typischen Toleranz des Produktes aus Stein.

**163x324**

64,17"x127,56"

**12 mm**

Impasto: Grigio  
Body: Grey



INF3644 Mont Blanc *full 3D texture\_A*  
INF3635 Mont Blanc *crystal polished\_A*

INF3645 Mont Blanc *full 3D texture\_B*  
INF3636 Mont Blanc *crystal polished\_B*

## 2 SURFACES

Full 3D Texture | Crystal Polished

L'effetto Bookmatch tra le diverse lastre è soggetto alla tolleranza tipica del prodotto lapideo.  
The bookmatching effect created by placing different slabs together is subject to the usual joint specifications of stone tiles. | L'effet Bookmatch entre différentes dalles est soumis à la tolérance typique du produit en pierre. | El efecto Bookmatch entre diferentes losas está sujeto a la tolerancia propia del producto pétreo. | Der Effekt des Bookmatching zwischen den verschiedenen Platten unterliegt der typischen Toleranz des Produktes aus Stein.

**163x324**

64,17"x127,56"

**12 mm**

Impasto: Bianco  
Body: White



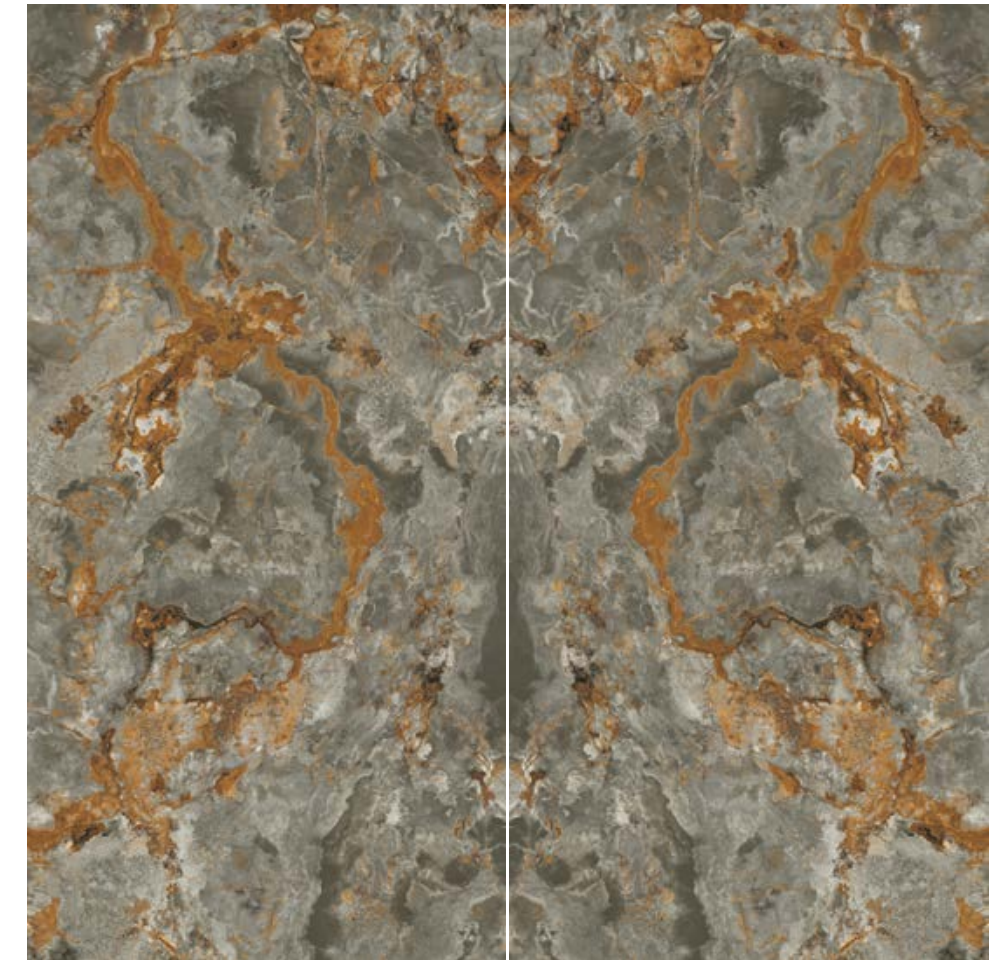
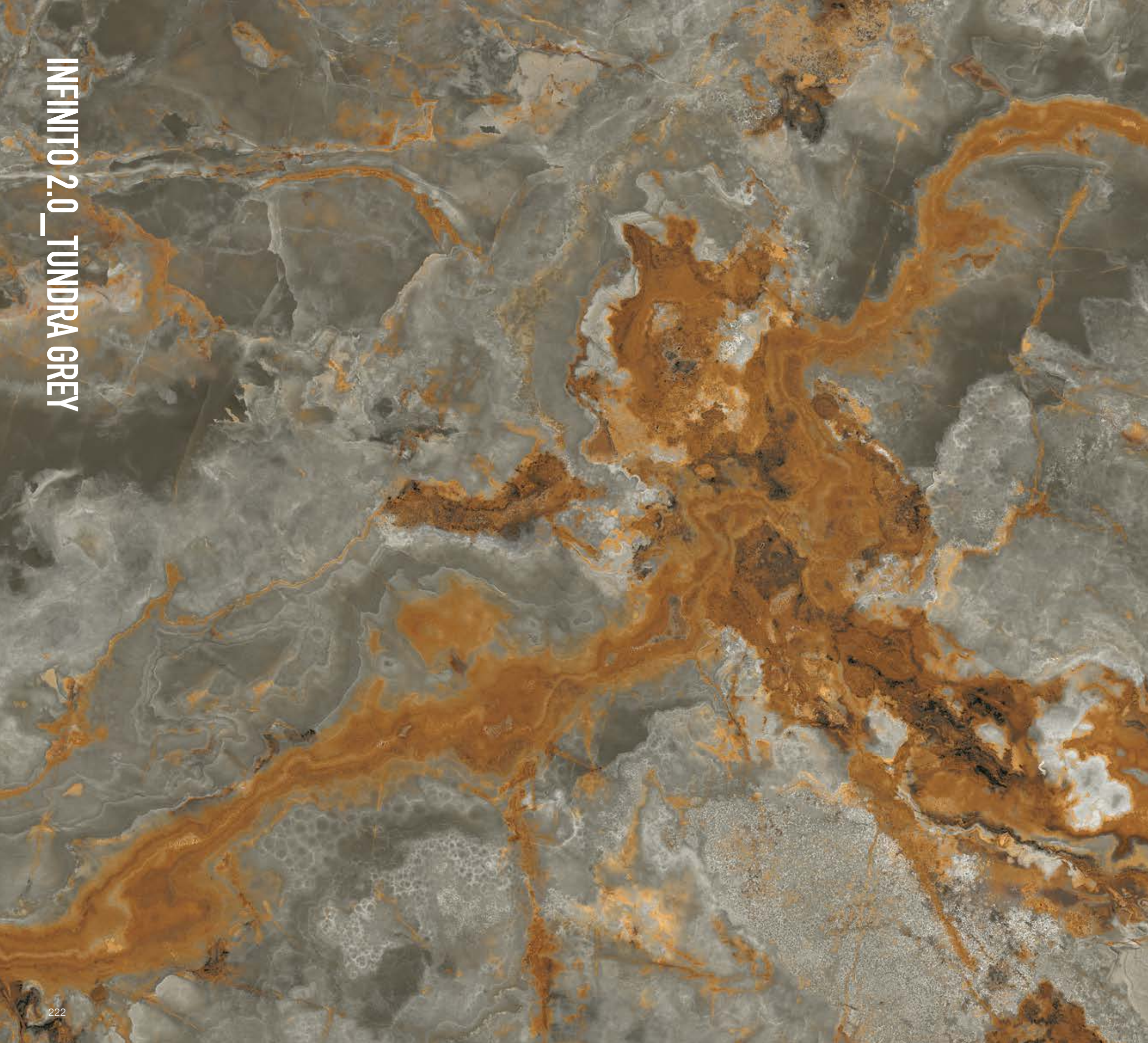

INF3626 Tundra Grey *polished\_A*

INF3627 Tundra Grey *polished\_B*

### 1 SURFACE

Polished

L'effetto Bookmatch tra le diverse lastre è soggetto alla tolleranza tipica del prodotto lapideo. The bookmatching effect created by placing different slabs together is subject to the usual joint specifications of stone tiles. | L'effet Bookmatch entre différentes dalles est soumis à la tolérance typique du produit en pierre. | El efecto Bookmatch entre diferentes losas está sujeto a la tolerancia propia del producto pétreo. | Der Effekt des Bookmatching zwischen den verschiedenen Platten unterliegt der typischen Toleranz des Produktes aus Stein.

**163x324**

64,17"x127,56"

**12 mm**

Impasto: Grigio  
Body: Grey



INF3651 Glacier full 3D texture

**1 SURFACE**  
Full 3D Texture

**163x324**  
64,17"x127,56"

**12 mm**

Impasto: Bianco  
Body: White

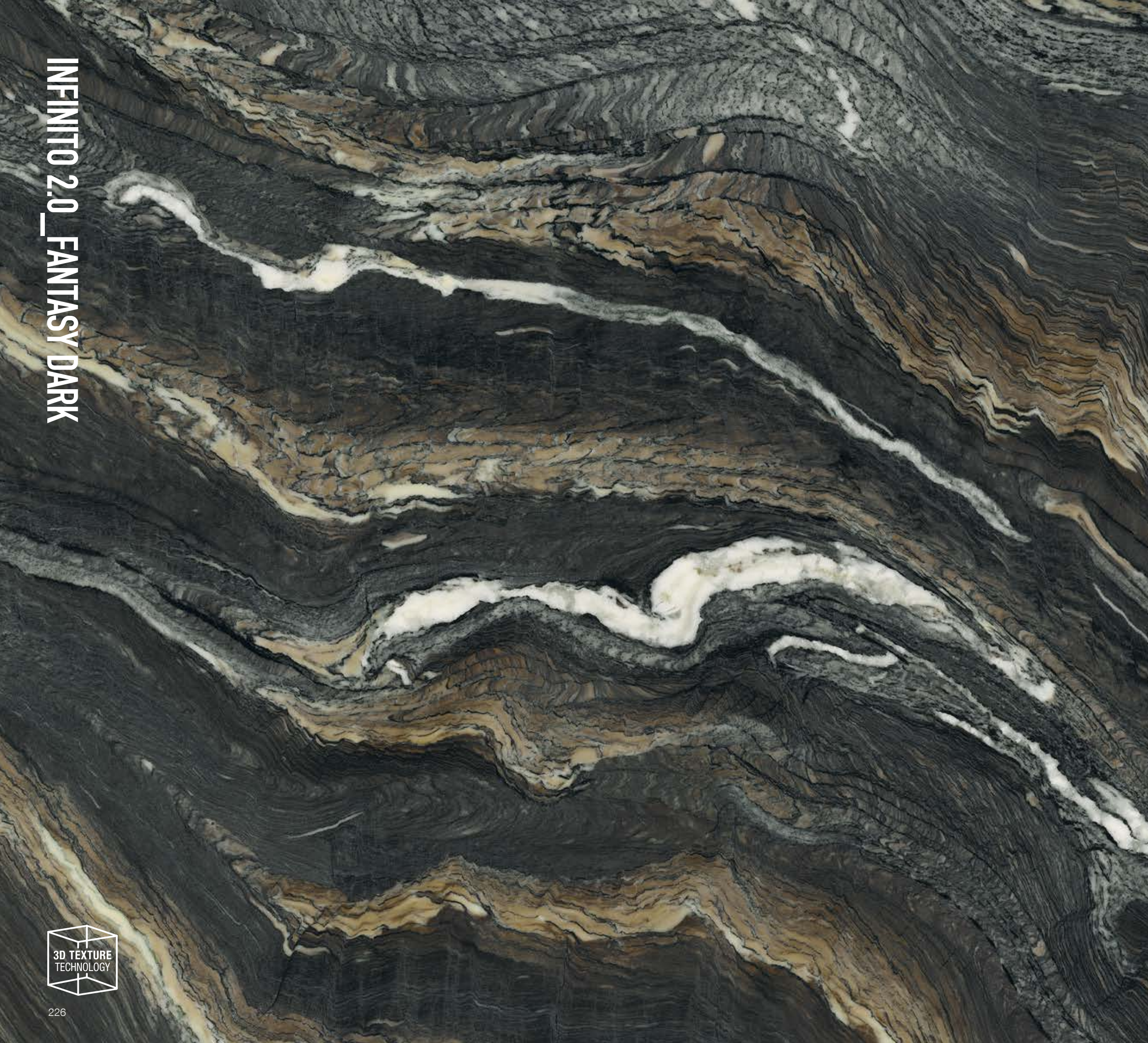

INF3696 Fantasy Dark full 3D texture\_A

INF3697 Fantasy Dark full 3D texture\_B

## 1 SURFACE

Full 3D Texture

L'effetto Bookmatch tra le diverse lastre è soggetto alla tolleranza tipica del prodotto lapideo.  
The bookmatching effect created by placing different slabs together is subject to the usual joint specifications of stone tiles. | L'effet Bookmatch entre différentes dalles est soumis à la tolérance typique du produit en pierre. | El efecto Bookmatch entre diferentes losas está sujeto a la tolerancia propia del producto pétreo. | Der Effekt des Bookmatching zwischen den verschiedenen Platten unterliegt der typischen Toleranz des Produktes aus Stein.

**163x324**

64,17"x127,56"

**12 mm**

Impasto: Nero  
Body: Black



**INF3481** Calacatta Vagli Oro  
*full 3D texture\_A*

**INF3417** Calacatta Vagli Oro  
*polished\_A*

## 2 SURFACES

Full 3D Texture | Polished

L'effetto Bookmatch tra le diverse lastre è soggetto alla tolleranza tipica del prodotto lapideo.  
The bookmatching effect created by placing different slabs together is subject to the usual joint specifications of stone tiles. | L'effet Bookmatch entre différentes dalles est soumis à la tolérance typique du produit en pierre. | El efecto Bookmatch entre diferentes losas está sujeto a la tolerancia propia del producto pétreo. | Der Effekt des Bookmatching zwischen den verschiedenen Platten unterliegt der typischen Toleranz des Produktes aus Stein.

**INF3482** Calacatta Vagli Oro  
*full 3D texture\_B*

**INF3418** Calacatta Vagli Oro  
*polished\_B*

**163x324**

64,17"x127,56"

**12 mm**

Impasto: Bianco  
Body: White





INF3617 Vitrum Light ALL-LIGHT polished\_A

INF3618 Vitrum Light ALL-LIGHT polished\_B

### 1 SURFACE

ALL-LIGHT Polished

**163x324**

64,17"x127,56"

**12 mm**

L'effetto Bookmatch tra le diverse lastre è soggetto alla tolleranza tipica del prodotto lapideo. The bookmatching effect created by placing different slabs together is subject to the usual joint specifications of stone tiles. | L'effet Bookmatch entre différentes dalles est soumis à la tolérance typique du produit en pierre. | El efecto Bookmatch entre diferentes losas está sujeto a la tolerancia propia del producto pétreo. | Der Effekt des Bookmatching zwischen den verschiedenen Platten unterliegt der typischen Toleranz des Produktes aus Stein.

Impasto: Bianco  
Body: White

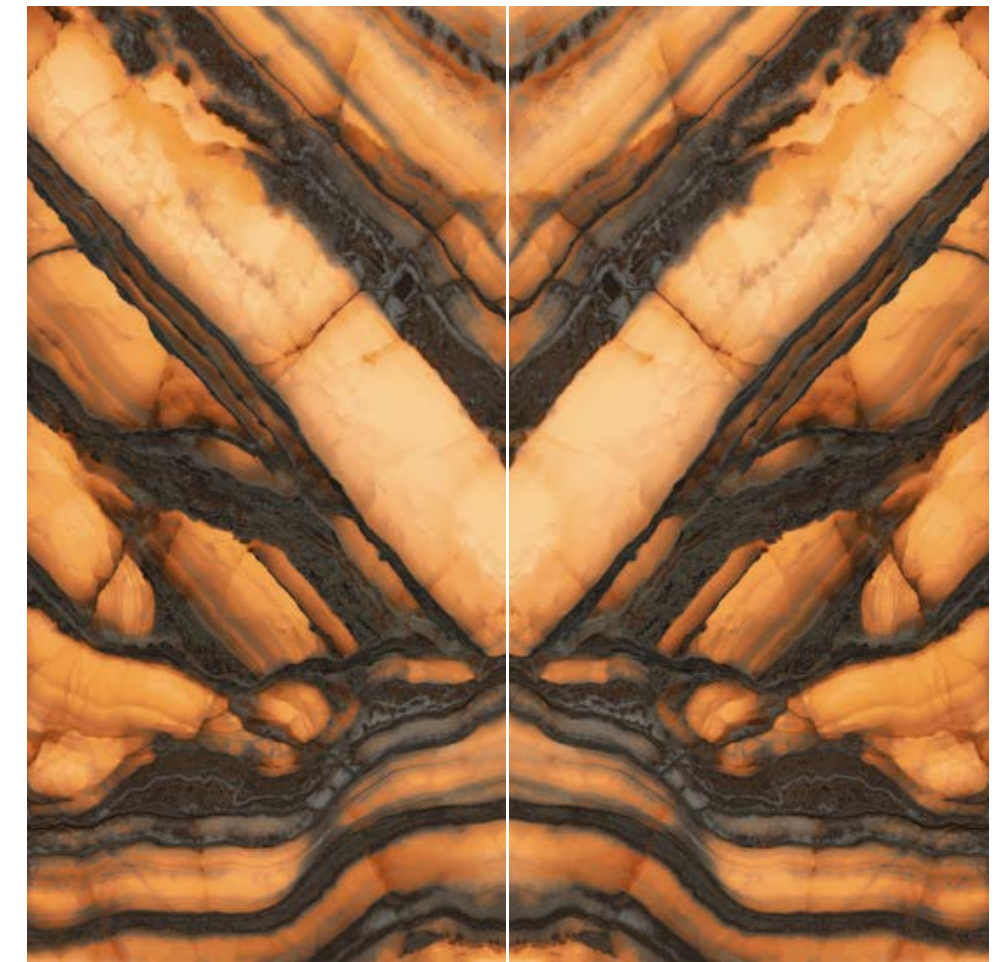
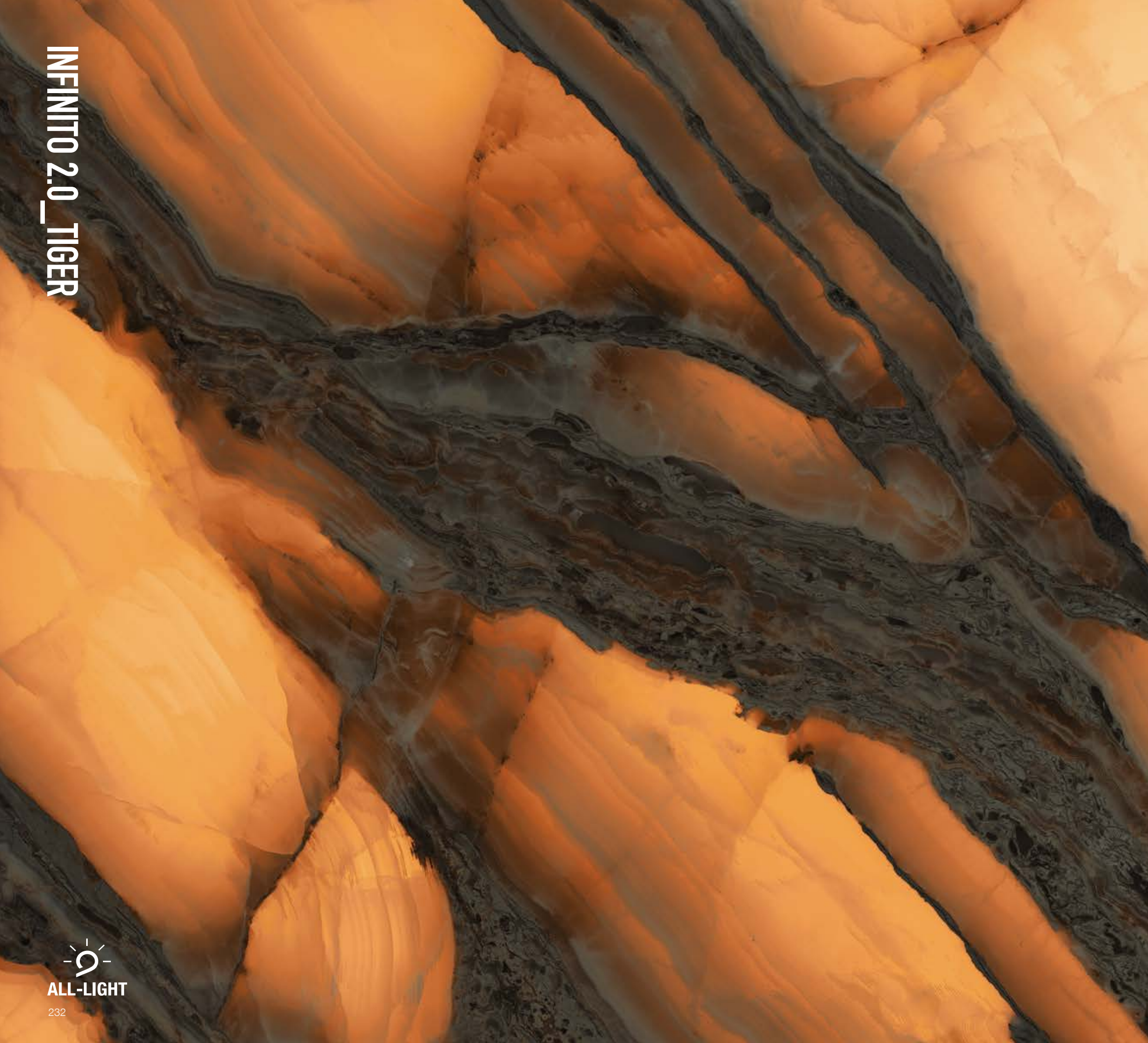

INF3161 Tiger ALL-LIGHT polished\_A

INF3162 Tiger ALL-LIGHT polished\_B

### 1 SURFACE

ALL-LIGHT Polished

L'effetto Bookmatch tra le diverse lastre è soggetto alla tolleranza tipica del prodotto lapideo.  
The bookmatching effect created by placing different slabs together is subject to the usual joint specifications of stone tiles. | L'effet Bookmatch entre différentes dalles est soumis à la tolérance typique du produit en pierre. | El efecto Bookmatch entre diferentes losas está sujeto a la tolerancia propia del producto pétreo. | Der Effekt des Bookmatching zwischen den verschiedenen Platten unterliegt der typischen Toleranz des Produktes aus Stein.

**163x324**

64,17"x127,56"

**12 mm**

Impasto: Bianco  
Body: White

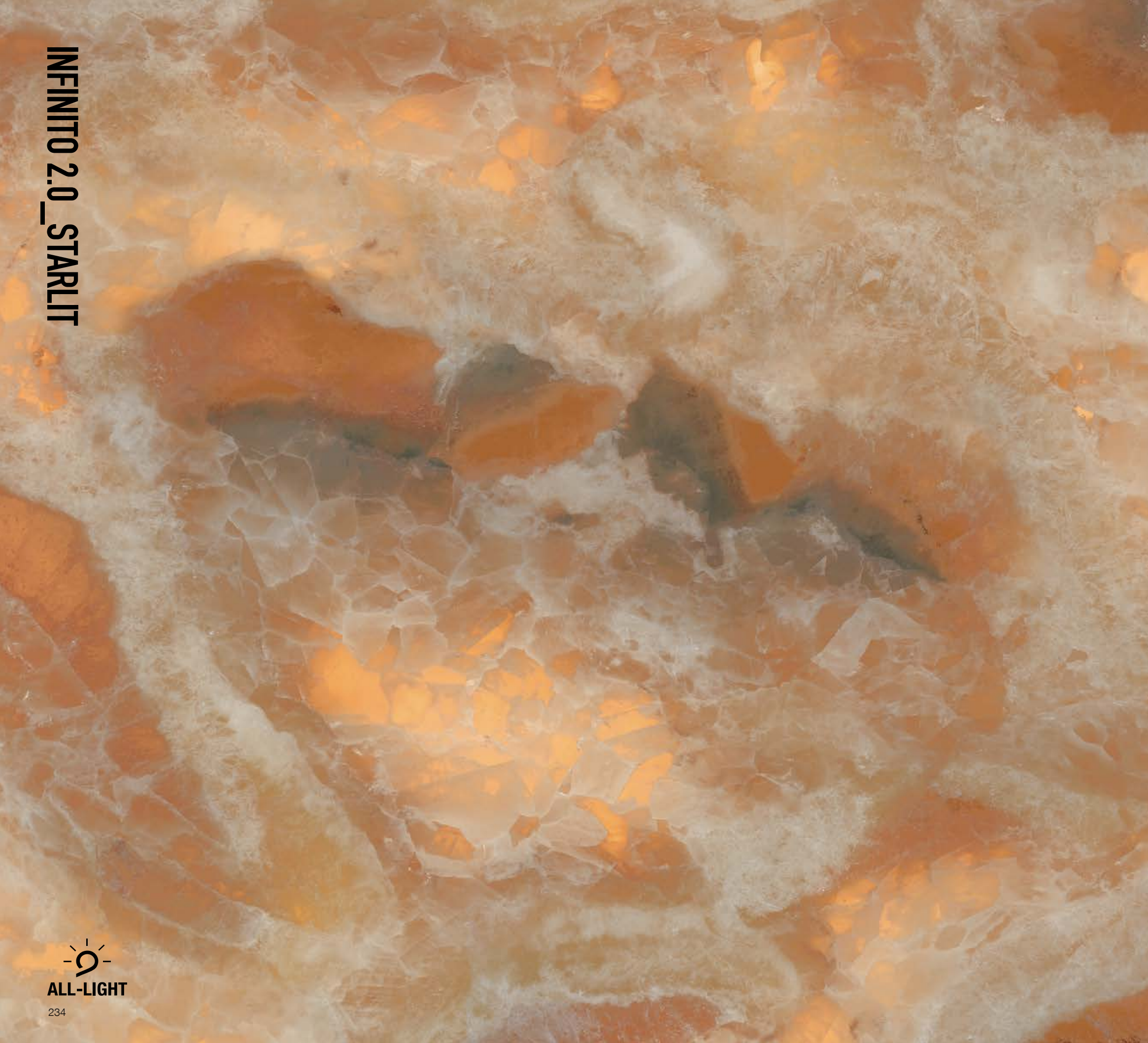

INF3170 Starlit ALL-LIGHT polished\_A

INF3171 Starlit ALL-LIGHT polished\_B

### 1 SURFACE

ALL-LIGHT Polished

**163x324**

64,17"x127,56"

**12 mm**

Impasto: Bianco  
Body: White

L'effetto Bookmatch tra le diverse lastre è soggetto alla tolleranza tipica del prodotto lapideo.  
The bookmatching effect created by placing different slabs together is subject to the usual joint specifications of stone tiles. | L'effet Bookmatch entre différentes dalles est soumis à la tolérance typique du produit en pierre. | El efecto Bookmatch entre diferentes losas está sujeto a la tolerancia propia del producto pétreo. | Der Effekt des Bookmatching zwischen den verschiedenen Platten unterliegt der typischen Toleranz des Produktes aus Stein.



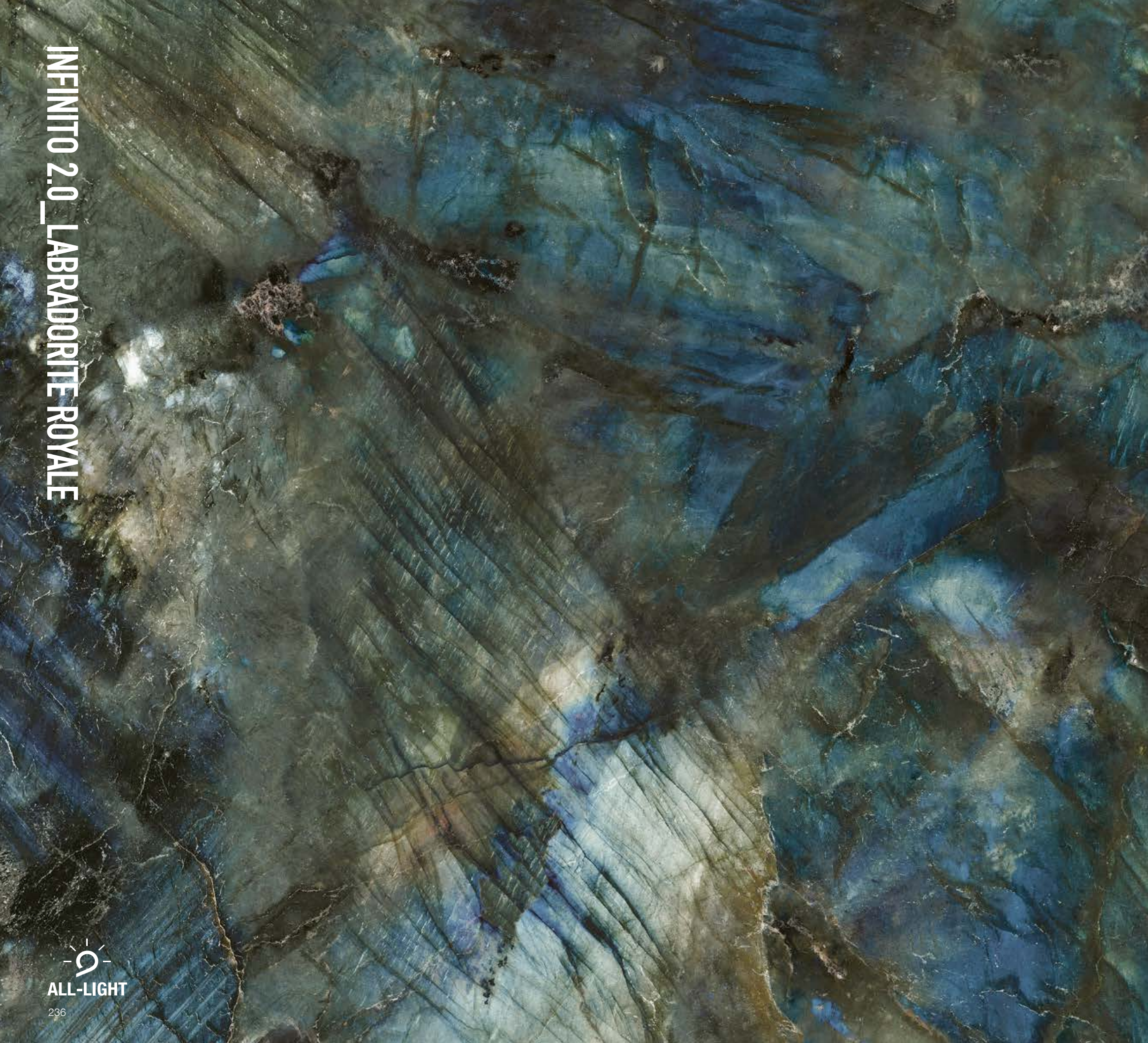

INF3179 Labradorite Royale ALL-LIGHT polished\_A    INF3180 Labradorite Royale ALL-LIGHT polished\_B

### 1 SURFACE

ALL-LIGHT Polished

**163x324**

64,17"x127,56"

**12 mm**

Impasto: Bianco  
Body: White

L'effetto Bookmatch tra le diverse lastre è soggetto alla tolleranza tipica del prodotto lapideo.  
The bookmatching effect created by placing different slabs together is subject to the usual joint specifications of stone tiles. | L'effet Bookmatch entre différentes dalles est soumis à la tolérance typique du produit en pierre. | El efecto Bookmatch entre diferentes losas está sujeto a la tolerancia propia del producto pétreo. | Der Effekt des Bookmatching zwischen den verschiedenen Platten unterliegt der typischen Toleranz des Produktes aus Stein.



INF3152 Calacatta Paris *full 3D texture\_A*  
INF3143 Calacatta Paris *polished\_A*

INF3153 Calacatta Paris *full 3D texture\_B*  
INF3144 Calacatta Paris *polished\_B*

## 2 SURFACES

Full 3D Texture | Polished

L'effetto Bookmatch tra le diverse lastre è soggetto alla tolleranza tipica del prodotto lapideo.  
The bookmatching effect created by placing different slabs together is subject to the usual joint specifications of stone tiles. | L'effet Bookmatch entre différentes dalles est soumis à la tolérance typique du produit en pierre. | El efecto Bookmatch entre diferentes losas está sujeto a la tolerancia propia del producto pétreo. | Der Effekt des Bookmatching zwischen den verschiedenen Platten unterliegt der typischen Toleranz des Produktes aus Stein.

**163x324**

64,17"x127,56"

**12 mm**

Impasto: Bianco  
Body: White



INF3261 Tiffany Green *polished\_A*

INF3262 Tiffany Green *polished\_B*

## 1 SURFACE

Polished

L'effetto Bookmatch tra le diverse lastre è soggetto alla tolleranza tipica del prodotto lapideo. The bookmatching effect created by placing different slabs together is subject to the usual joint specifications of stone tiles. | L'effet Bookmatch entre différentes dalles est soumis à la tolérance typique du produit en pierre. | El efecto Bookmatch entre diferentes losas está sujeto a la tolerancia propia del producto pétreo. | Der Effekt des Bookmatching zwischen den verschiedenen Platten unterliegt der typischen Toleranz des Produktes aus Stein.

**163x324**

64,17"x127,56"

**12 mm**

Impasto: Bianco  
Body: White

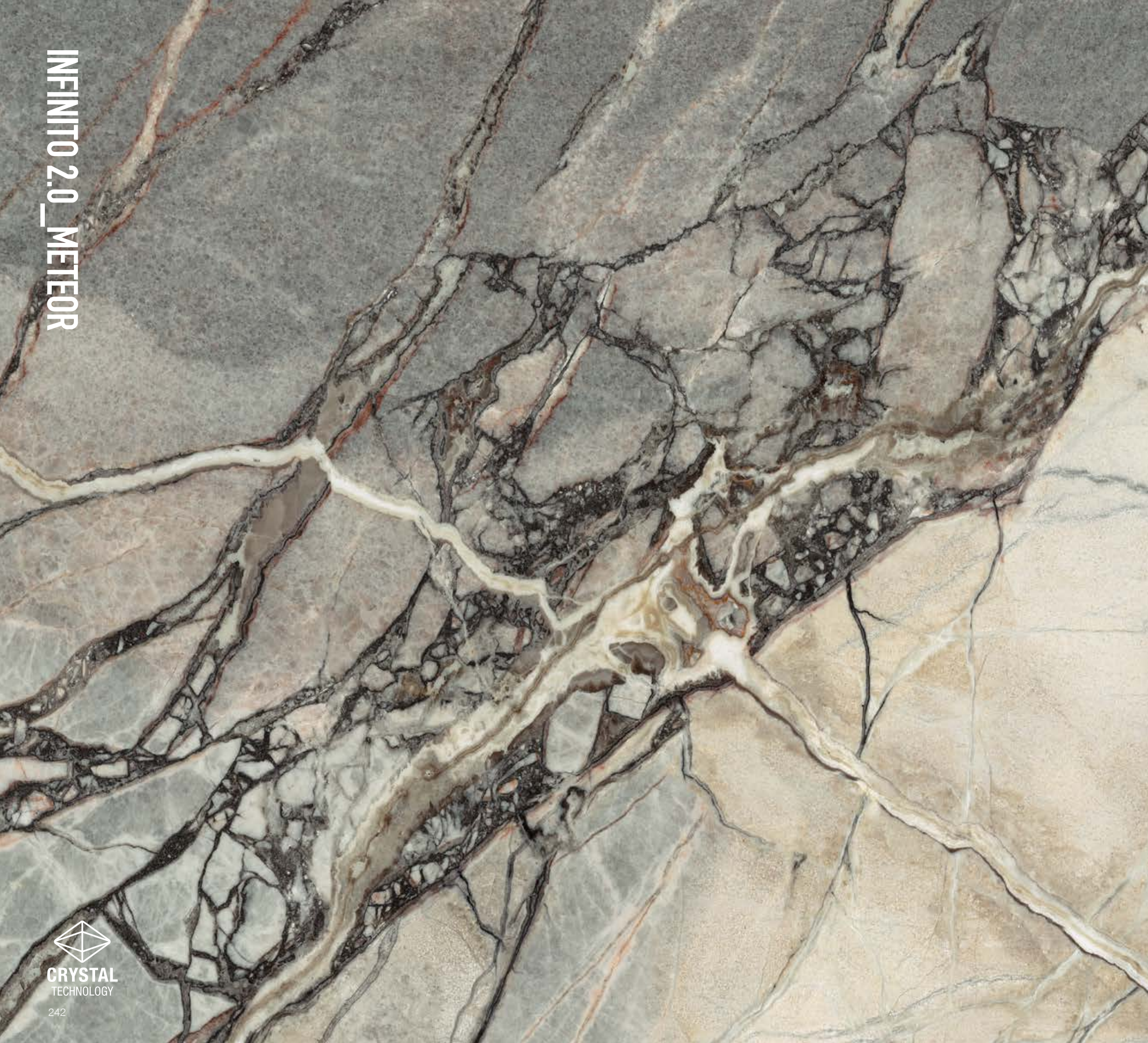

INF2883 Meteor *crystal polished\_A*

INF2884 Meteor *crystal polished\_B*

### 1 SURFACE

Crystal Polished

**163x324**

64,17"x127,56"

**12 mm**

**Impasto: Bianco**  
Body: White

L'effetto Bookmatch tra le diverse lastre è soggetto alla tolleranza tipica del prodotto lapideo.  
The bookmatching effect created by placing different slabs together is subject to the usual joint specifications of stone tiles. | L'effet Bookmatch entre différentes dalles est soumis à la tolérance typique du produit en pierre. | El efecto Bookmatch entre diferentes losas está sujeto a la tolerancia propia del producto pétreo. | Der Effekt des Bookmatching zwischen den verschiedenen Platten unterliegt der typischen Toleranz des Produktes aus Stein.

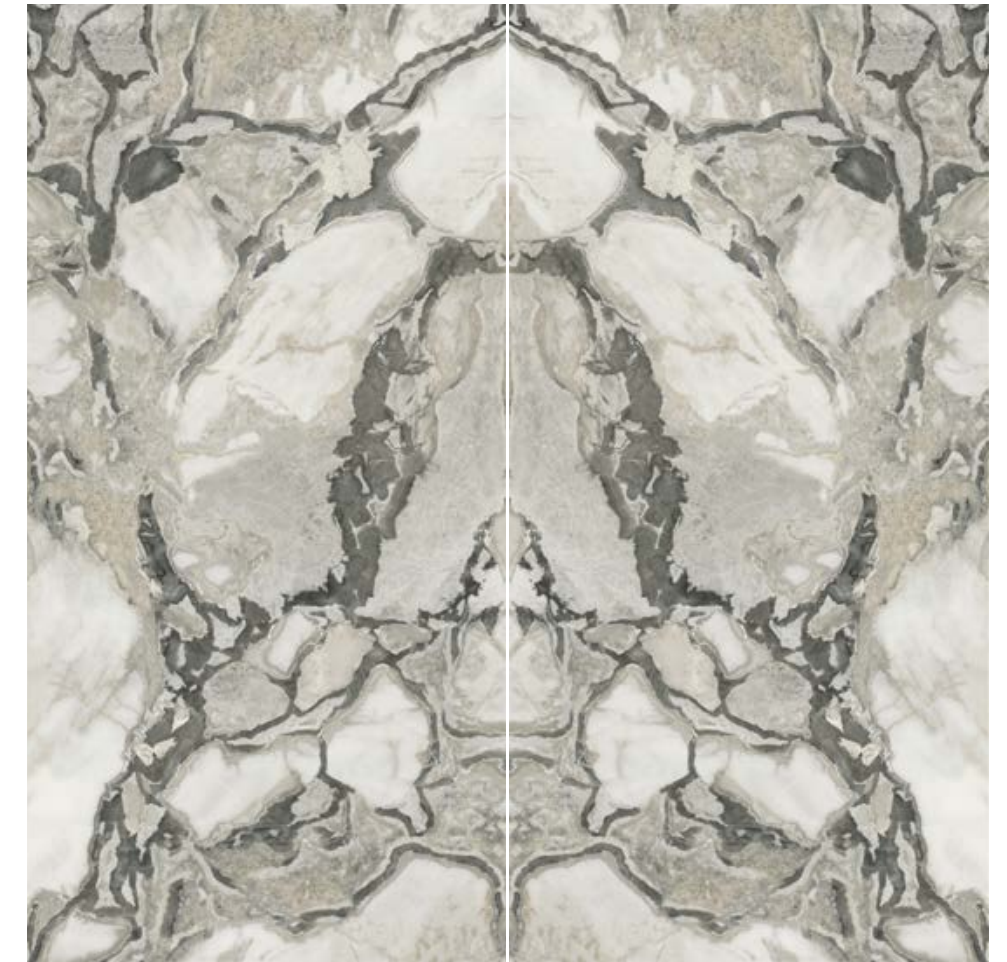

INF2524 Cliff White full 3D texture\_A

INF2525 Cliff White full 3D texture\_B

**1 SURFACE**

Full 3D Texture

**163x324**

64,17"x127,56"

**12 mm**

**Impasto: Bianco**  
Body: White

L'effetto Bookmatch tra le diverse lastre è soggetto alla tolleranza tipica del prodotto lapideo.  
The bookmatching effect created by placing different slabs together is subject to the usual joint specifications of stone tiles. | L'effet Bookmatch entre différentes dalles est soumis à la tolérance typique du produit en pierre. | El efecto Bookmatch entre diferentes losas está sujeto a la tolerancia propia del producto pétreo. | Der Effekt des Bookmatching zwischen den verschiedenen Platten unterliegt der typischen Toleranz des Produktes aus Stein.





INF2526 Cream Diamonds *full 3D texture\_A*      INF2527 Cream Diamonds *full 3D texture\_B*  
INF3086 Cream Diamonds *full 3D texture polished\_A*      INF3087 Cream Diamonds *full 3D texture polished\_B*

## 2 SURFACES

Full 3D Texture | Full 3D Texture Polished

L'effetto Bookmatch tra le diverse lastre è soggetto alla tolleranza tipica del prodotto lapideo.  
The bookmatching effect created by placing different slabs together is subject to the usual joint specifications of stone tiles. | L'effet Bookmatch entre différentes dalles est soumis à la tolérance typique du produit en pierre. | El efecto Bookmatch entre diferentes losas está sujeto a la tolerancia propia del producto pétreo. | Der Effekt des Bookmatching zwischen den verschiedenen Platten unterliegt der typischen Toleranz des Produktes aus Stein.

**163x324**

64,17"x127,56"

**12 mm**

Impasto: Bianco  
Body: White





INF2517 Breccia Van Gogh *polished\_A*

INF2518 Breccia Van Gogh *polished\_B*

### 1 SURFACE

Polished

L'effetto Bookmatch tra le diverse lastre è soggetto alla tolleranza tipica del prodotto lapideo. The bookmatching effect created by placing different slabs together is subject to the usual joint specifications of stone tiles. | L'effet Bookmatch entre différentes dalles est soumis à la tolérance typique du produit en pierre. | El efecto Bookmatch entre diferentes losas está sujeto a la tolerancia propia del producto pétreo. | Der Effekt des Bookmatching zwischen den verschiedenen Platten unterliegt der typischen Toleranz des Produktes aus Stein.

**163x324**

64,17"x127,56"

**12 mm**

**Impasto: Grigio**  
Body: Grey



INF2497 Luxury Gold *polished\_A*

INF2498 Luxury Gold *polished\_B*

### 1 SURFACE

Polished

L'effetto Bookmatch tra le diverse lastre è soggetto alla tolleranza tipica del prodotto lapideo.  
The bookmatching effect created by placing different slabs together is subject to the usual joint specifications of stone tiles. | L'effet Bookmatch entre différentes dalles est soumis à la tolérance typique du produit en pierre. | El efecto Bookmatch entre diferentes losas está sujeto a la tolerancia propia del producto pétreo. | Der Effekt des Bookmatching zwischen den verschiedenen Platten unterliegt der typischen Toleranz des Produktes aus Stein.

**163x324**

64,17"x127,56"

**12 mm**

Impasto: Bianco  
Body: White



INF2307 Patagonia *natural\_A*  
INF1441 Patagonia *polished\_A*

INF2308 Patagonia *natural\_B*  
INF1442 Patagonia *polished\_B*

## 2 SURFACES

Natural | Polished

L'effetto Bookmatch tra le diverse lastre è soggetto alla tolleranza tipica del prodotto lapideo.  
The bookmatching effect created by placing different slabs together is subject to the usual joint specifications of stone tiles. | L'effet Bookmatch entre différentes dalles est soumis à la tolérance typique du produit en pierre. | El efecto Bookmatch entre diferentes losas está sujeto a la tolerancia propia del producto pétreo. | Der Effekt des Bookmatching zwischen den verschiedenen Platten unterliegt der typischen Toleranz des Produktes aus Stein.

**163x324**

64,17"x127,56"

**12 mm**

Impasto: Bianco  
Body: White



INF2169 Royal Creamy *natural\_A*

INF2170 Royal Creamy *natural\_B*

### 1 SURFACE

Natural

L'effetto Bookmatch tra le diverse lastre è soggetto alla tolleranza tipica del prodotto lapideo. The bookmatching effect created by placing different slabs together is subject to the usual joint specifications of stone tiles. | L'effet Bookmatch entre différentes dalles est soumis à la tolérance typique du produit en pierre. | El efecto Bookmatch entre diferentes losas está sujeto a la tolerancia propia del producto pétreo. | Der Effekt des Bookmatching zwischen den verschiedenen Platten unterliegt der typischen Toleranz des Produktes aus Stein.

**163x324**

64,17"x127,56"

**12 mm**

Impasto: Grigio  
Body: Grey



INF539 Fior Di Bosco *honed*  
INF540 Fior Di Bosco *polished*

**2 SURFACES**

Honed | Polished

**163x324**

64,17"x127,56"

**12 mm**

Impasto: Grigio  
Body: Grey

La superficie HONED è una finitura di nuova concezione che risulta più opaca rispetto alla versione POLISHED. Le differenze di lucentezza ed eventuali disomogeneità di aspetto sono quindi da considerare caratteristiche intrinseche di questa superficie.

The HONED surface is a new finish that gives a more matt effect than the POLISHED version. Any differences in shine and appearance are therefore a natural feature of this surface finish.

INFINITO 2.0\_ONICE WHITE

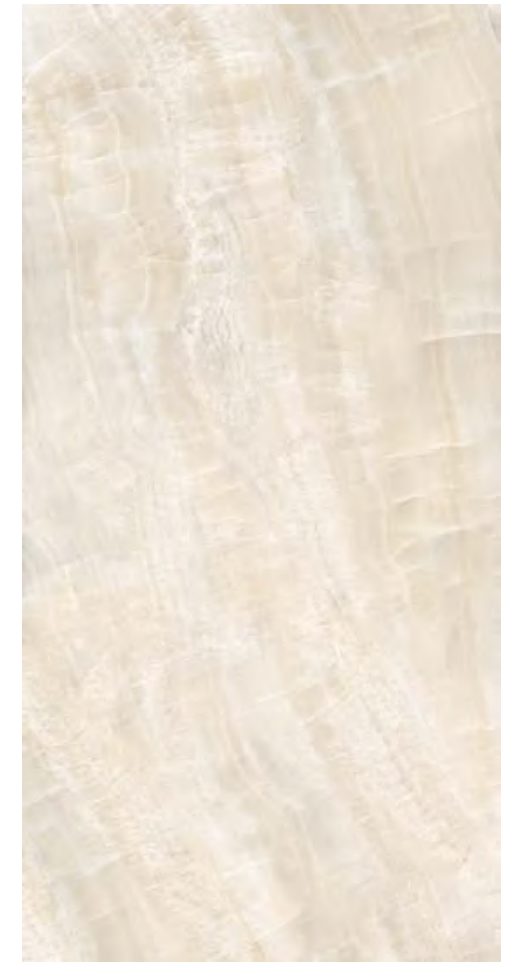

INF3435 Onice White *natural*  
INF1226 Onice White *polished*

**2 SURFACES**  
Natural | Polished

**163x324**  
64,17"x127,56"

**12 mm**

Impasto: Bianco  
Body: White



# INFINITO 2.0\_TAJ MAHAL LIGHT



INF3190 Taj Mahal Light *natural\_A*  
INF3084 Taj Mahal Light *polished\_A*

INF3191 Taj Mahal Light *natural\_B*  
INF3085 Taj Mahal Light *polished\_B*

## 2 SURFACES

Natural | Polished

L'effetto Bookmatch tra le diverse lastre è soggetto alla tolleranza tipica del prodotto lapideo.  
The bookmatching effect created by placing different slabs together is subject to the usual joint specifications of stone tiles. | L'effet Bookmatch entre différentes dalles est soumis à la tolérance typique du produit en pierre. | El efecto Bookmatch entre diferentes losas está sujeto a la tolerancia propia del producto pétreo. | Der Effekt des Bookmatching zwischen den verschiedenen Platten unterliegt der typischen Toleranz des Produktes aus Stein.

**163x324**

64,17"x127,56"

**12 mm**

Impasto: Bianco  
Body: White



INF2046 Taj Mahal *polished\_A*

INF2047 Taj Mahal *polished\_B*

### 1 SURFACE

Polished

L'effetto Bookmatch tra le diverse lastre è soggetto alla tolleranza tipica del prodotto lapideo. The bookmatching effect created by placing different slabs together is subject to the usual joint specifications of stone tiles. | L'effet Bookmatch entre différentes dalles est soumis à la tolérance typique du produit en pierre. | El efecto Bookmatch entre diferentes losas está sujeto a la tolerancia propia del producto pétreo. | Der Effekt des Bookmatching zwischen den verschiedenen Platten unterliegt der typischen Toleranz des Produktes aus Stein.

**163x324**

64,17"x127,56"

**12 mm**

Impasto: Bianco  
Body: White

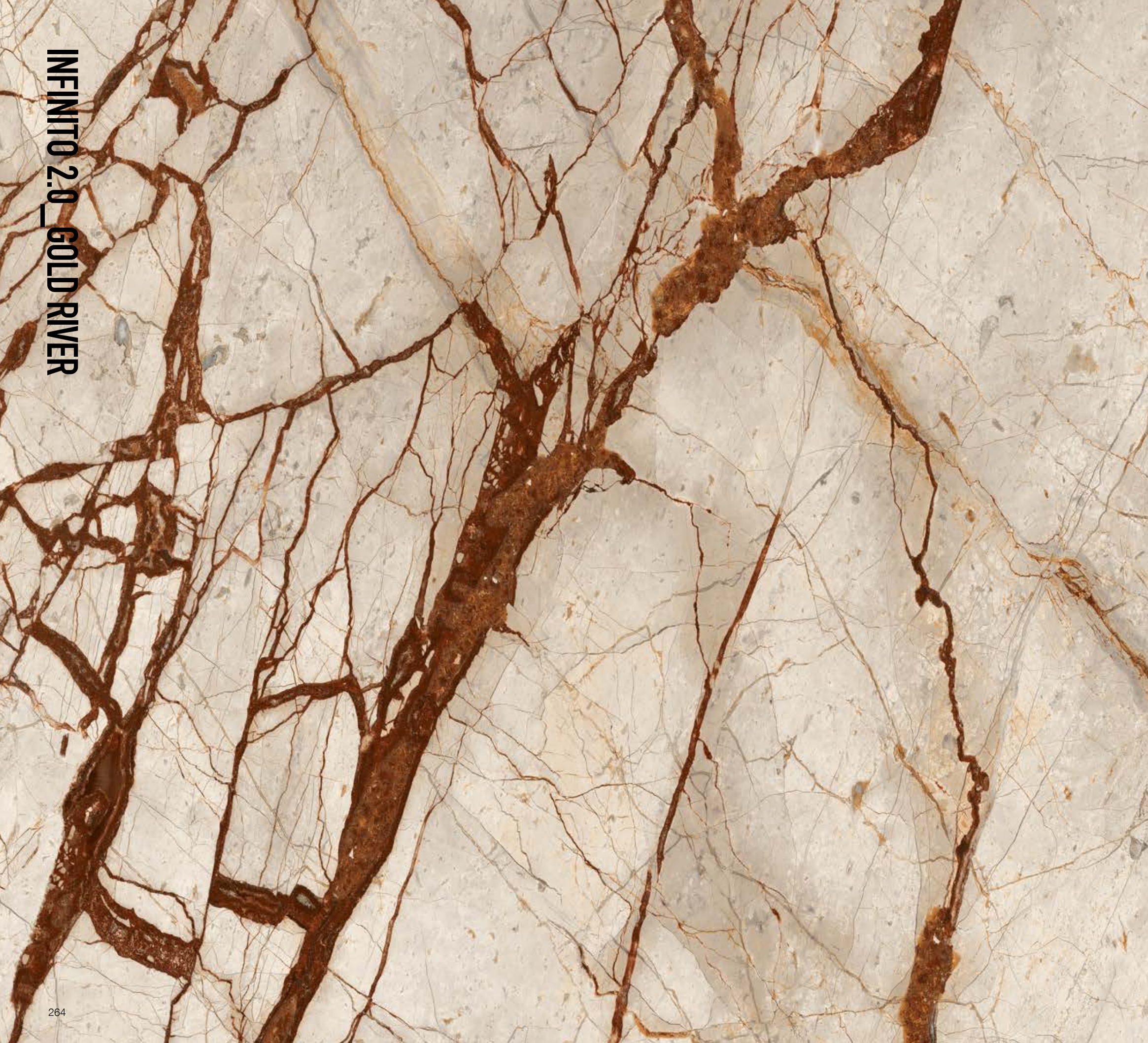

INF2238 Gold River *polished\_A*

INF2330 Gold River *polished\_B*

## 1 SURFACE

Polished

L'effetto Bookmatch tra le diverse lastre è soggetto alla tolleranza tipica del prodotto lapideo. The bookmatching effect created by placing different slabs together is subject to the usual joint specifications of stone tiles. | L'effet Bookmatch entre différentes dalles est soumis à la tolérance typique du produit en pierre. | El efecto Bookmatch entre diferentes losas está sujeto a la tolerancia propia del producto pétreo. | Der Effekt des Bookmatching zwischen den verschiedenen Platten unterliegt der typischen Toleranz des Produktes aus Stein.

**163x324**

64,17"x127,56"

**12 mm**

Impasto: Bianco  
Body: White



INF2309 Golden Spider *polished\_A*

INF2310 Golden Spider *polished\_B*

### 1 SURFACE

Polished

L'effetto Bookmatch tra le diverse lastre è soggetto alla tolleranza tipica del prodotto lapideo. | The bookmatching effect created by placing different slabs together is subject to the usual joint specifications of stone tiles. | L'effet Bookmatch entre différentes dalles est soumis à la tolérance typique du produit en pierre. | El efecto Bookmatch entre diferentes losas está sujeto a la tolerancia propia del producto pétreo. | Der Effekt des Bookmatching zwischen den verschiedenen Platten unterliegt der typischen Toleranz des Produktes aus Stein.

**163x324**

64,17"x127,56"

**12 mm**

Impasto: Bianco  
Body: White

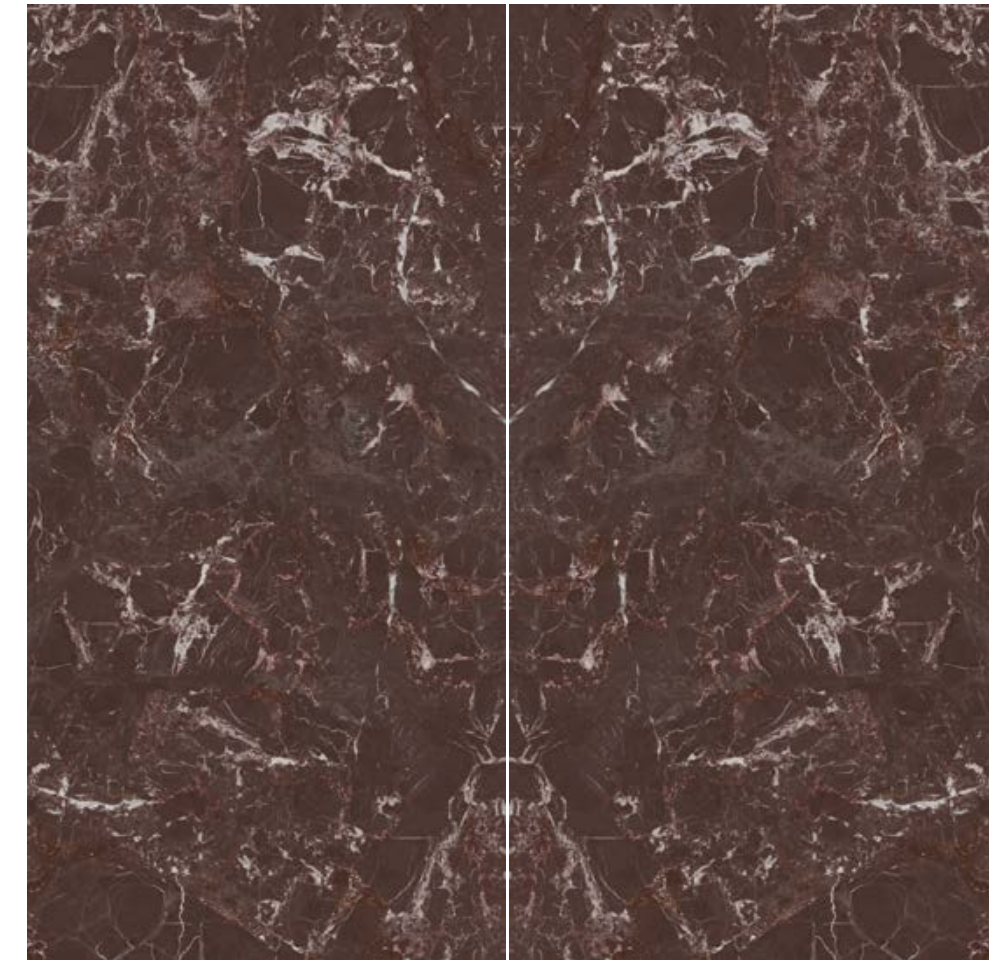

INF2515 Rosso Lepanto *polished\_A*

INF2516 Rosso Lepanto *polished\_B*

## 1 SURFACE

Polished

L'effetto Bookmatch tra le diverse lastre è soggetto alla tolleranza tipica del prodotto lapideo. | The bookmatching effect created by placing different slabs together is subject to the usual joint specifications of stone tiles. | L'effet Bookmatch entre différentes dalles est soumis à la tolérance typique du produit en pierre. | El efecto Bookmatch entre diferentes losas está sujeto a la tolerancia propia del producto pétreo. | Der Effekt des Bookmatching zwischen den verschiedenen Platten unterliegt der typischen Toleranz des Produktes aus Stein.

**163x324**

64,17"x127,56"

**12 mm**

**Impasto: Nero**  
Body: Black



INF3440 Calacatta Viola *natural\_A*  
INF2511 Calacatta Viola *polished\_A*

INF3441 Calacatta Viola *natural\_B*  
INF2512 Calacatta Viola *polished\_B*

## 2 SURFACES

Natural | Polished

L'effetto Bookmatch tra le diverse lastre è soggetto alla tolleranza tipica del prodotto lapideo.  
The bookmatching effect created by placing different slabs together is subject to the usual joint specifications of stone tiles. | L'effet Bookmatch entre différentes dalles est soumis à la tolérance typique du produit en pierre. | El efecto Bookmatch entre diferentes losas está sujeto a la tolerancia propia del producto pétreo. | Der Effekt des Bookmatching zwischen den verschiedenen Platten unterliegt der typischen Toleranz des Produktes aus Stein.

**163x324**

64,17"x127,56"

**12 mm**

Impasto: Bianco  
Body: White



INF2295 Capraia *natural\_A*  
 INF1198 Capraia *honed\_A*  
 INF1200 Capraia *polished\_A*

INF2296 Capraia *natural\_B*  
 INF1199 Capraia *honed\_B*  
 INF1201 Capraia *polished\_B*

### 3 SURFACES

Natural | Honed | Polished

La superficie HONED è una finitura di nuova concezione che risulta più opaca rispetto alla versione POLISHED. Le differenze di lucentezza ed eventuali disomogeneità di aspetto sono quindi da considerare caratteristiche intrinseche di questa superficie.

The HONED surface is a new finish that gives a more matt effect than the POLISHED version. Any differences in shine and appearance are therefore a natural feature of this surface finish.

L'effetto Bookmatch tra le diverse lastre è soggetto alla tolleranza tipica del prodotto lapideo. The bookmatching effect created by placing different slabs together is subject to the usual joint specifications of stone tiles. | L'effet Bookmatch entre différentes dalles est soumis à la tolérance typique du produit en pierre. | El efecto Bookmatch entre diferentes losas está sujeto a la tolerancia propia del producto pétreo. | Der Effekt des Bookmatching zwischen den verschiedenen Platten unterliegt der typischen Toleranz des Produktes aus Stein.

**163x324**

64,17"x127,56"

**12 mm**

Impasto: Bianco  
 Body: White



INF2889 Thassos *crystal polished*

**1 SURFACE**  
Crystal Polished

**163x324**  
64,17"x127,56"

**12 mm**

Impasto: Bianco  
Body: White



INF2872 Statuarietto *natural*

**1 SURFACE**  
Natural

**163x324**  
64,17"x127,56"

**12 mm**

Impasto: Bianco  
Body: White



INF2304 Elegant White *natural\_A*

INF2305 Elegant White *natural\_B*

### 1 SURFACE

Natural

L'effetto Bookmatch tra le diverse lastre è soggetto alla tolleranza tipica del prodotto lapideo.  
The bookmatching effect created by placing different slabs together is subject to the usual joint specifications of stone tiles. | L'effet Bookmatch entre différentes dalles est soumis à la tolérance typique du produit en pierre. | El efecto Bookmatch entre diferentes losas está sujeto a la tolerancia propia del producto pétreo. | Der Effekt des Bookmatching zwischen den verschiedenen Platten unterliegt der typischen Toleranz des Produktes aus Stein.

**163x324**

64,17"x127,56"

**12 mm**

Impasto: Bianco  
Body: White



INF1079 Carrara C *honed*  
INF1080 Carrara C *polished*

**2 SURFACES**  
Honed | Polished

**163x324**  
64,17"x127,56"

La superficie HONED è una finitura di nuova concezione che risulta più opaca rispetto alla versione POLISHED. Le differenze di lucentezza ed eventuali disomogeneità di aspetto sono quindi da considerare caratteristiche intrinseche di questa superficie.  
The HONED surface is a new finish that gives a more matt effect than the POLISHED version. Any differences in shine and appearance are therefore a natural feature of this surface finish.

**12 mm**  
Impasto: Bianco  
Body: White

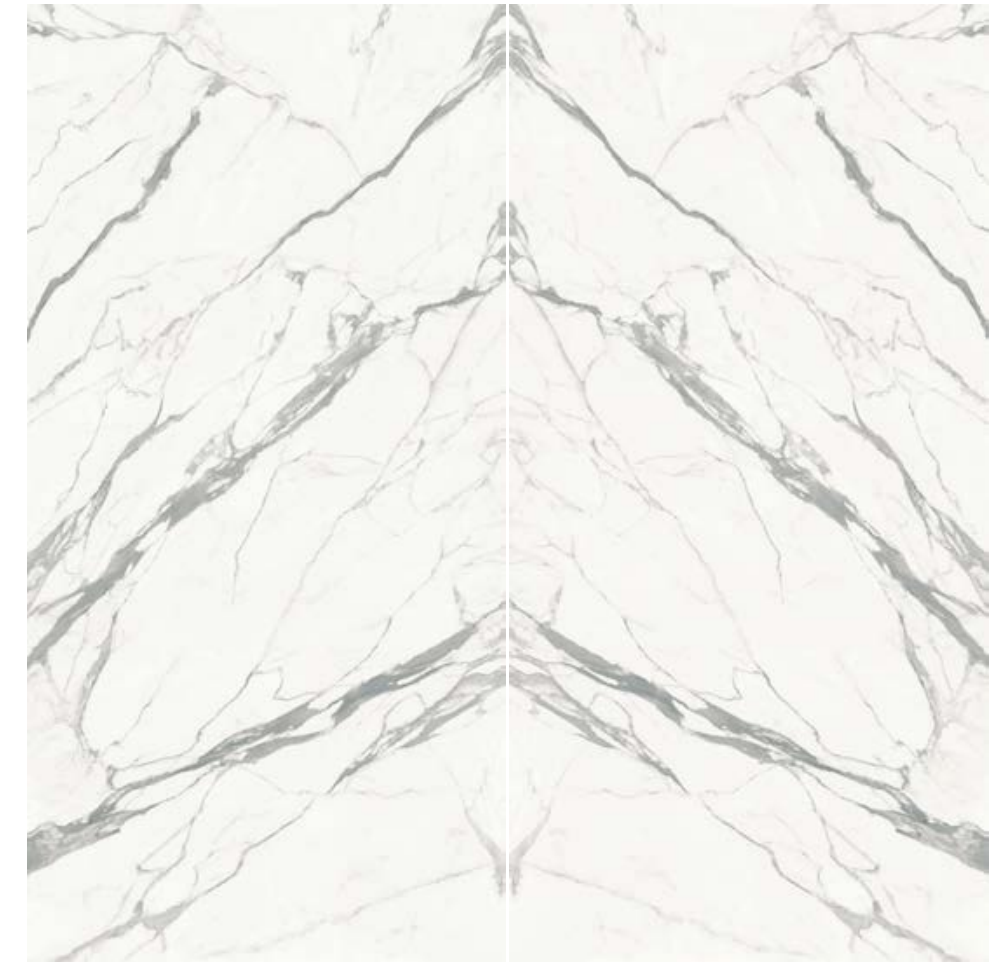

INF1464 Statuario Extra *natural\_12mm\_A*  
 INF937 Statuario Extra *honed\_12mm\_A*  
 INF938 Statuario Extra *polished\_12mm\_A*  
 INF1382 Statuario Extra *natural\_20mm\_A*  
 INF1384 Statuario Extra *polished\_20mm\_A*

INF1465 Statuario Extra *natural\_12mm\_B*  
 INF939 Statuario Extra *honed\_12mm\_B*  
 INF940 Statuario Extra *polished\_12mm\_B*  
 INF1383 Statuario Extra *natural\_20mm\_B*  
 INF1385 Statuario Extra *polished\_20mm\_B*

### 3 SURFACES

Natural | Honed | Polished

La superficie HONED è una finitura di nuova concezione che risulta più opaca rispetto alla versione POLISHED. Le differenze di lucentezza ed eventuali disomogeneità di aspetto sono quindi da considerare caratteristiche intrinseche di questa superficie.  
 The HONED surface is a new finish that gives a more matt effect than the POLISHED version. Any differences in shine and appearance are therefore a natural feature of this surface finish.

L'effetto Bookmatch tra le diverse lastre è soggetto alla tolleranza tipica del prodotto lapideo.  
 The bookmatching effect created by placing different slabs together is subject to the usual joint specifications of stone tiles. | L'effet Bookmatch entre différentes dalles est soumis à la tolérance typique du produit en pierre. | El efecto Bookmatch entre diferentes losas está sujeto a la tolerancia propia del producto pétreo. | Der Effekt des Bookmatching zwischen den verschiedenen Platten unterliegt der typischen Toleranz des Produktes aus Stein.

**163x324**

64,17"x127,56"

**12/20 mm**

Impasto: Bianco  
 Body: White



INF2863 Lincoln *natural\_A*

INF2305 Lincoln *natural\_B*

### 1 SURFACE

Natural

L'effetto Bookmatch tra le diverse lastre è soggetto alla tolleranza tipica del prodotto lapideo. The bookmatching effect created by placing different slabs together is subject to the usual joint specifications of stone tiles. | L'effet Bookmatch entre différentes dalles est soumis à la tolérance typique du produit en pierre. | El efecto Bookmatch entre diferentes losas está sujeto a la tolerancia propia del producto pétreo. | Der Effekt des Bookmatching zwischen den verschiedenen Platten unterliegt der typischen Toleranz des Produktes aus Stein.

**163x324**

64,17"x127,56"

**12 mm**

Impasto: Bianco  
Body: White



INF433 Calacatta White *honed\_A*  
INF434 Calacatta White *polished\_A*

INF437 Calacatta White *honed\_B*  
INF438 Calacatta White *polished\_B*

## 2 SURFACES

Honed | Polished

La superficie HONED è una finitura di nuova concezione che risulta più opaca rispetto alla versione POLISHED. Le differenze di lucentezza ed eventuali disomogeneità di aspetto sono quindi da considerare caratteristiche intrinseche di questa superficie.  
The HONED surface is a new finish that gives a more matt effect than the POLISHED version. Any differences in shine and appearance are therefore a natural feature of this surface finish.

L'effetto Bookmatch tra le diverse lastre è soggetto alla tolleranza tipica del prodotto lapideo.  
The bookmatching effect created by placing different slabs together is subject to the usual joint specifications of stone tiles. | L'effet Bookmatch entre différentes dalles est soumis à la tolérance typique du produit en pierre. | El efecto Bookmatch entre diferentes losas está sujeto a la tolerancia propia del producto pétreo. | Der Effekt des Bookmatching zwischen den verschiedenen Platten unterliegt der typischen Toleranz des Produktes aus Stein.

**163x324**

64,17"x127,56"

**12 mm**

Impasto: Bianco  
Body: White



INF2536 Calacatta Light *natural\_12mm\_A*  
 INF1213 Calacatta Light *honed\_12mm\_A*  
 INF1215 Calacatta Light *polished\_12mm\_A*  
 INF1358 Calacatta Light *natural\_20mm\_A*  
 INF1360 Calacatta Light *polished\_20mm\_A*

INF2858 Calacatta Light *natural\_12mm\_B*  
 INF1214 Calacatta Light *honed\_12mm\_B*  
 INF1216 Calacatta Light *polished\_12mm\_B*  
 INF1359 Calacatta Light *natural\_20mm\_B*  
 INF1361 Calacatta Light *polished\_20mm\_B*

### 3 SURFACES

Natural | Honed | Polished

La superficie HONED è una finitura di nuova concezione che risulta più opaca rispetto alla versione POLISHED. Le differenze di lucentezza ed eventuali disomogeneità di aspetto sono quindi da considerare caratteristiche intrinseche di questa superficie.

The HONED surface is a new finish that gives a more matt effect than the POLISHED version. Any differences in shine and appearance are therefore a natural feature of this surface finish.

L'effetto Bookmatch tra le diverse lastre è soggetto alla tolleranza tipica del prodotto lapideo. The bookmatching effect created by placing different slabs together is subject to the usual joint specifications of stone tiles. | L'effet Bookmatch entre différentes dalles est soumis à la tolérance typique du produit en pierre. | El efecto Bookmatch entre diferentes losas está sujeto a la tolerancia propia del producto pétreo. | Der Effekt des Bookmatching zwischen den verschiedenen Platten unterliegt der typischen Toleranz des Produktes aus Stein.

**163x324**

64,17"x127,56"

**12/20 mm**

Impasto: Bianco  
 Body: White



INF3134 Calacatta Venice *natural\_A*  
INF3125 Calacatta Venice *polished\_A*

INF3135 Calacatta Venice *natural\_B*  
INF3126 Calacatta Venice *polished\_B*

## 2 SURFACES

Natural | Polished

L'effetto Bookmatch tra le diverse lastre è soggetto alla tolleranza tipica del prodotto lapideo. The bookmatching effect created by placing different slabs together is subject to the usual joint specifications of stone tiles. | L'effet Bookmatch entre différentes dalles est soumis à la tolérance typique du produit en pierre. | El efecto Bookmatch entre diferentes losas está sujeto a la tolerancia propia del producto pétreo. | Der Effekt des Bookmatching zwischen den verschiedenen Platten unterliegt der typischen Toleranz des Produktes aus Stein.

**163x324**

64,17"x127,56"

**12 mm**

Impasto: Bianco  
Body: White



INF1470 Calacatta Gold *natural\_12mm\_A*  
 INF448 Calacatta Gold *honed\_12mm\_A*  
 INF449 Calacatta Gold *polished\_12mm\_A*  
 INF1370 Calacatta Gold *natural\_20mm\_A*  
 INF1372 Calacatta Gold *polished\_20mm\_A*

INF1471 Calacatta Gold *natural\_12mm\_B*  
 INF452 Calacatta Gold *honed\_12mm\_B*  
 INF453 Calacatta Gold *polished\_12mm\_B*  
 INF1371 Calacatta Gold *natural\_20mm\_B*  
 INF1373 Calacatta Gold *polished\_20mm\_B*

### 3 SURFACES

Natural | Honed | Polished

La superficie HONED è una finitura di nuova concezione che risulta più opaca rispetto alla versione POLISHED. Le differenze di lucentezza ed eventuali disomogeneità di aspetto sono quindi da considerare caratteristiche intrinseche di questa superficie.

The HONED surface is a new finish that gives a more matt effect than the POLISHED version. Any differences in shine and appearance are therefore a natural feature of this surface finish.

L'effetto Bookmatch tra le diverse lastre è soggetto alla tolleranza tipica del prodotto lapideo. The bookmatching effect created by placing different slabs together is subject to the usual joint specifications of stone tiles. | L'effet Bookmatch entre différentes dalles est soumis à la tolérance typique du produit en pierre. | El efecto Bookmatch entre diferentes losas está sujeto a la tolerancia propia del producto pétreo. | Der Effekt des Bookmatching zwischen den verschiedenen Platten unterliegt der typischen Toleranz des Produktes aus Stein.

**163x324**

64,17"x127,56"

**12/20 mm**

Impasto: Bianco  
 Body: White



INF2853 Calacatta Macchia Vecchia *natural\_A*  
INF2171 Calacatta Macchia Vecchia *polished\_A*

INF2854 Calacatta Macchia Vecchia *natural\_B*  
INF2172 Calacatta Macchia Vecchia *polished\_B*

## 2 SURFACES

Natural | Polished

L'effetto Bookmatch tra le diverse lastre è soggetto alla tolleranza tipica del prodotto lapideo.  
The bookmatching effect created by placing different slabs together is subject to the usual joint specifications of stone tiles. | L'effet Bookmatch entre différentes dalles est soumis à la tolérance typique du produit en pierre. | El efecto Bookmatch entre diferentes losas está sujeto a la tolerancia propia del producto pétreo. | Der Effekt des Bookmatching zwischen den verschiedenen Platten unterliegt der typischen Toleranz des Produktes aus Stein.

**163x324**

64,17"x127,56"

**12 mm**

Impasto: Bianco  
Body: White



INF2157 Super White *natural\_A*  
INF2522 Super White *polished\_A*

INF2158 Super White *natural\_B*  
INF2523 Super White *polished\_B*

## 2 SURFACES

Natural | Polished

L'effetto Bookmatch tra le diverse lastre è soggetto alla tolleranza tipica del prodotto lapideo. The bookmatching effect created by placing different slabs together is subject to the usual joint specifications of stone tiles. | L'effet Bookmatch entre différentes dalles est soumis à la tolérance typique du produit en pierre. | El efecto Bookmatch entre diferentes losas está sujeto a la tolerancia propia del producto pétreo. | Der Effekt des Bookmatching zwischen den verschiedenen Platten unterliegt der typischen Toleranz des Produktes aus Stein.

**163x324**

64,17"x127,56"

**12 mm**

Impasto: Bianco  
Body: White



INF2418 Calacatta Green *polished\_A*

INF2419 Calacatta Green *polished\_B*

### 1 SURFACE

Polished

L'effetto Bookmatch tra le diverse lastre è soggetto alla tolleranza tipica del prodotto lapideo. The bookmatching effect created by placing different slabs together is subject to the usual joint specifications of stone tiles. | L'effet Bookmatch entre différentes dalles est soumis à la tolérance typique du produit en pierre. | El efecto Bookmatch entre diferentes losas está sujeto a la tolerancia propia del producto pétreo. | Der Effekt des Bookmatching zwischen den verschiedenen Platten unterliegt der typischen Toleranz des Produktes aus Stein.

**163x324**

64,17"x127,56"

**12 mm**

Impasto: Bianco  
Body: White

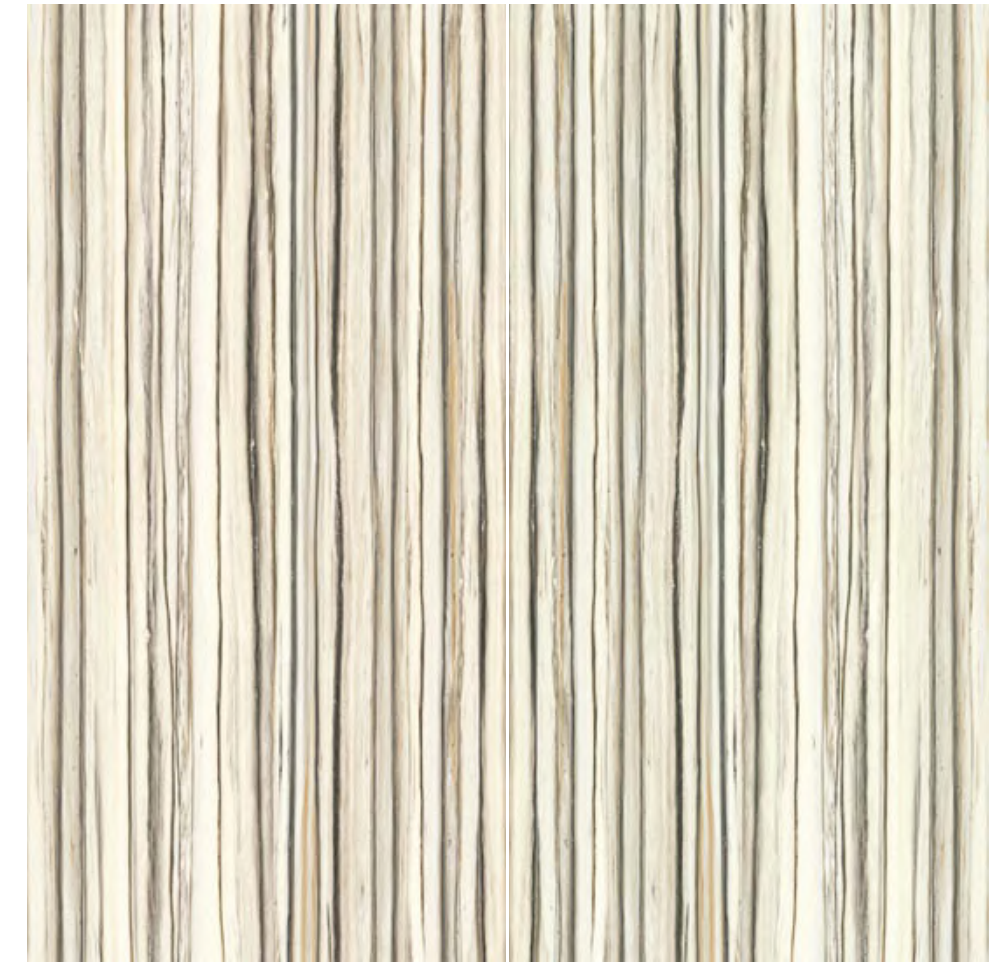

INF1453 Zebрино *polished\_A*

INF1454 Zebрино *polished\_B*

## 1 SURFACE

Polished

L'effetto Bookmatch tra le diverse lastre è soggetto alla tolleranza tipica del prodotto lapideo. The bookmatching effect created by placing different slabs together is subject to the usual joint specifications of stone tiles. | L'effet Bookmatch entre différentes dalles est soumis à la tolérance typique du produit en pierre. | El efecto Bookmatch entre diferentes losas está sujeto a la tolerancia propia del producto pétreo. | Der Effekt des Bookmatching zwischen den verschiedenen Platten unterliegt der typischen Toleranz des Produktes aus Stein.

**163x324**

64,17"x127,56"

**12 mm**

Impasto: Bianco  
Body: White

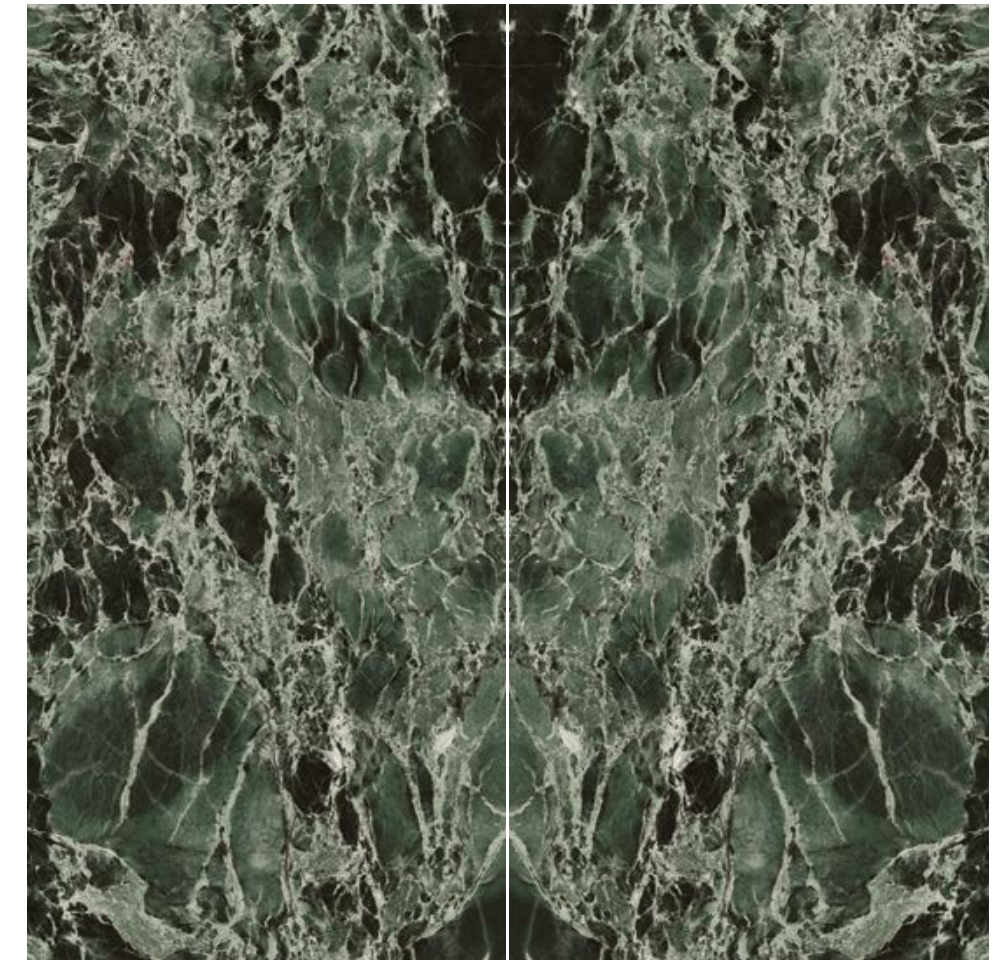
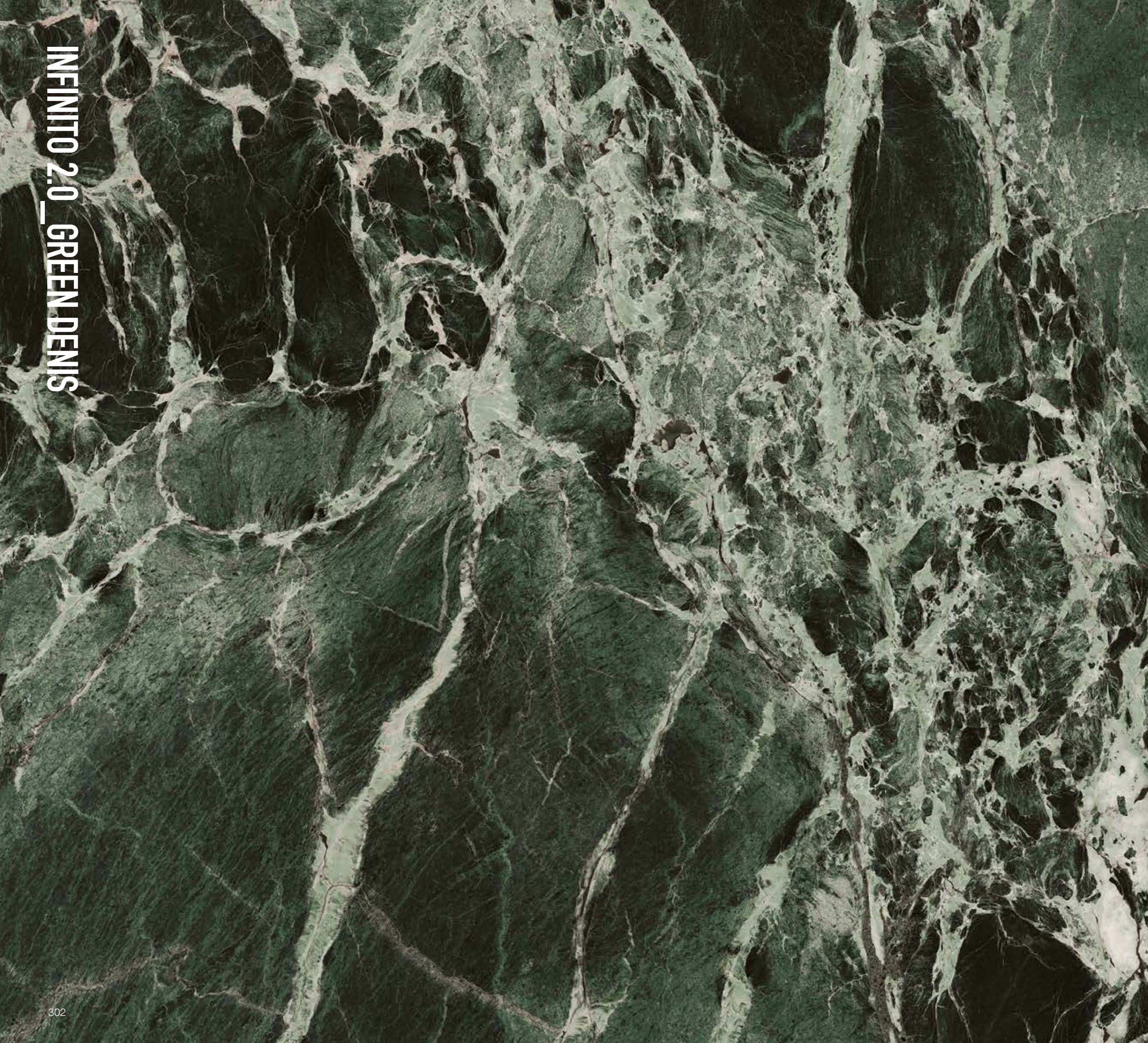

INF2455 Green Denis *polished\_A*

INF2456 Green Denis *polished\_B*

## 1 SURFACE

Polished

L'effetto Bookmatch tra le diverse lastre è soggetto alla tolleranza tipica del prodotto lapideo. | The bookmatching effect created by placing different slabs together is subject to the usual joint specifications of stone tiles. | L'effet Bookmatch entre différentes dalles est soumis à la tolérance typique du produit en pierre. | El efecto Bookmatch entre diferentes losas está sujeto a la tolerancia propia del producto pétreo. | Der Effekt des Bookmatching zwischen den verschiedenen Platten unterliegt der typischen Toleranz des Produktes aus Stein.

**163x324**

64,17"x127,56"

**12 mm**

Impasto: Nero  
Body: Black

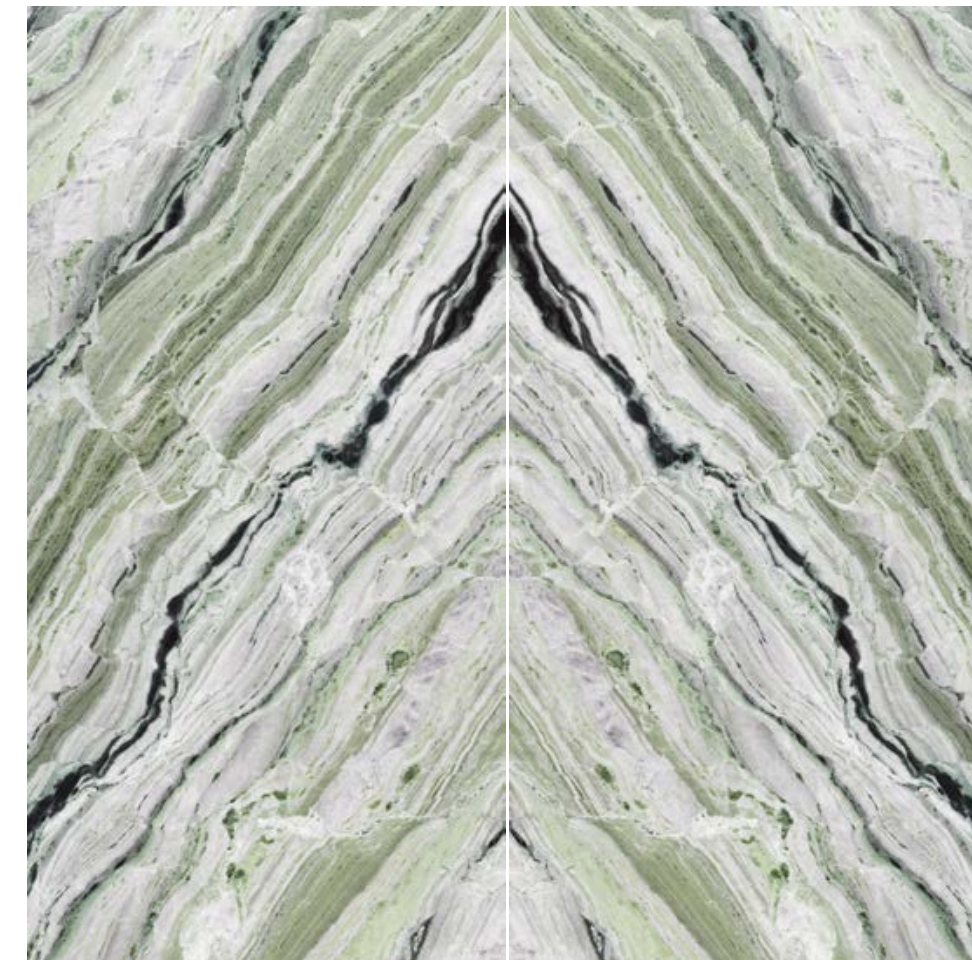

INF2519 River Jade *polished\_A*

INF2520 River Jade *polished\_B*

### 1 SURFACE

Polished

L'effetto Bookmatch tra le diverse lastre è soggetto alla tolleranza tipica del prodotto lapideo. The bookmatching effect created by placing different slabs together is subject to the usual joint specifications of stone tiles. | L'effet Bookmatch entre différentes dalles est soumis à la tolérance typique du produit en pierre. | El efecto Bookmatch entre diferentes losas está sujeto a la tolerancia propia del producto pétreo. | Der Effekt des Bookmatching zwischen den verschiedenen Platten unterliegt der typischen Toleranz des Produktes aus Stein.

**163x324**

64,17"x127,56"

**12 mm**

Impasto: Bianco  
Body: White



INF2521 Emerald Green *polished*

**1 SURFACE**  
Polished

**163x324**  
64,17"x127,56"

**12 mm**

Impasto: Bianco  
Body: White



INF2439 Amazonite *polished\_A*

INF2440 Amazonite *polished\_B*

### 1 SURFACE

Polished

L'effetto Bookmatch tra le diverse lastre è soggetto alla tolleranza tipica del prodotto lapideo.  
The bookmatching effect created by placing different slabs together is subject to the usual joint specifications of stone tiles. | L'effet Bookmatch entre différentes dalles est soumis à la tolérance typique du produit en pierre. | El efecto Bookmatch entre diferentes losas está sujeto a la tolerancia propia del producto pétreo. | Der Effekt des Bookmatching zwischen den verschiedenen Platten unterliegt der typischen Toleranz des Produktes aus Stein.

**163x324**

64,17"x127,56"

**12 mm**

Impasto: Grigio  
Body: Grey



INF2306 Blue Roma *honed*  
INF2385 Blue Roma *polished*

**2 SURFACES**

Honed | Polished

**163x324**

64,17"x127,56"

**12 mm**

Impasto: Grigio  
Body: Grey

La superficie HONED è una finitura di nuova concezione che risulta più opaca rispetto alla versione POLISHED. Le differenze di lucentezza ed eventuali disomogeneità di aspetto sono quindi da considerare caratteristiche intrinseche di questa superficie.

The HONED surface is a new finish that gives a more matt effect than the POLISHED version. Any differences in shine and appearance are therefore a natural feature of this surface finish.

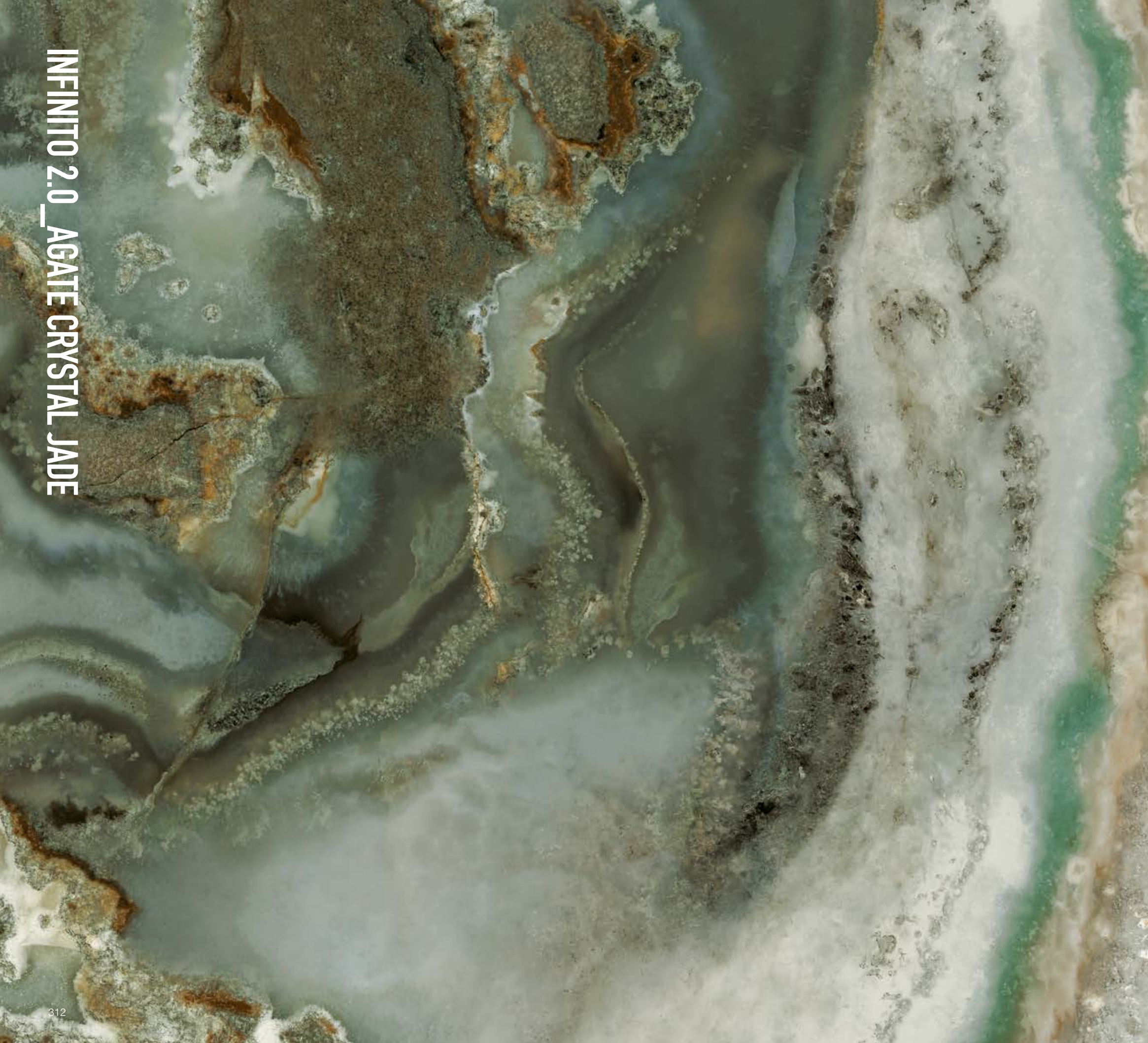

INF2435 Agate Crystal Jade *polished\_A*

INF2436 Agate Crystal Jade *polished\_B*

### 1 SURFACE

Polished

L'effetto Bookmatch tra le diverse lastre è soggetto alla tolleranza tipica del prodotto lapideo. The bookmatching effect created by placing different slabs together is subject to the usual joint specifications of stone tiles. | L'effet Bookmatch entre différentes dalles est soumis à la tolérance typique du produit en pierre. | El efecto Bookmatch entre diferentes losas está sujeto a la tolerancia propia del producto pétreo. | Der Effekt des Bookmatching zwischen den verschiedenen Platten unterliegt der typischen Toleranz des Produktes aus Stein.

**163x324**

64,17"x127,56"

**12 mm**

Impasto: Grigio  
Body: Grey

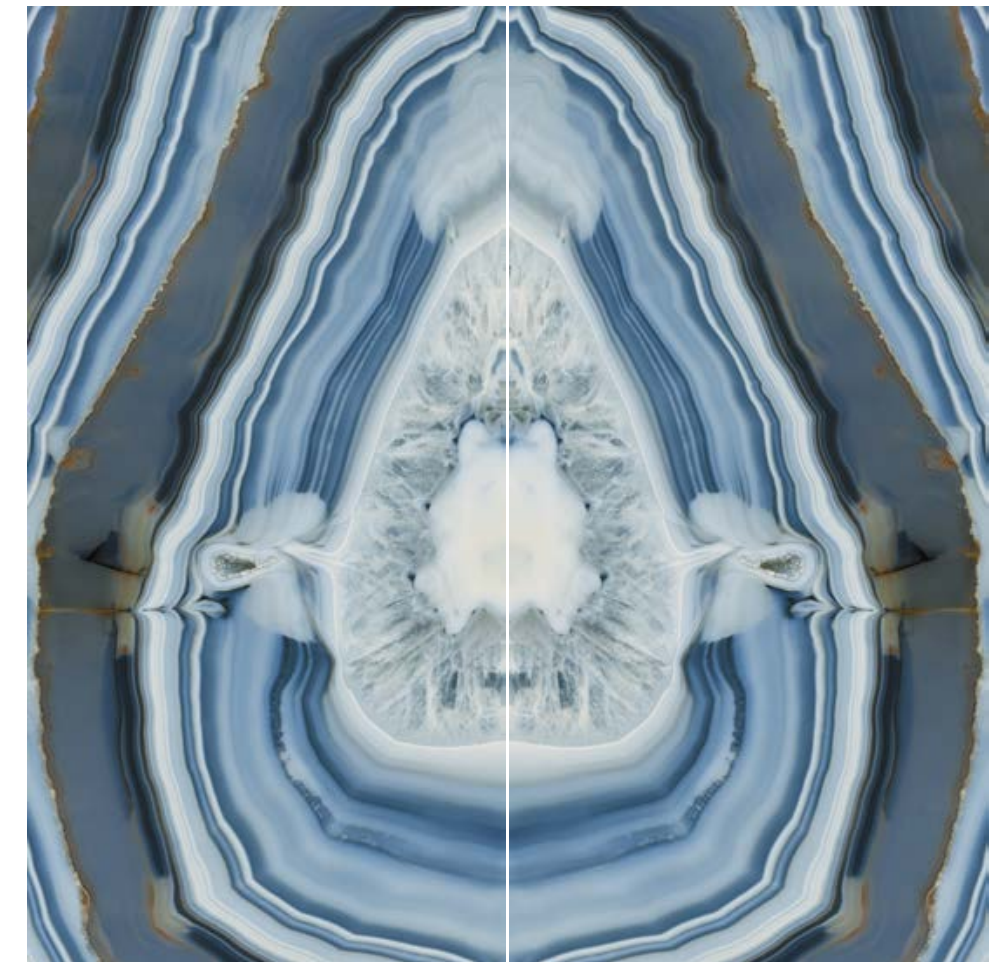
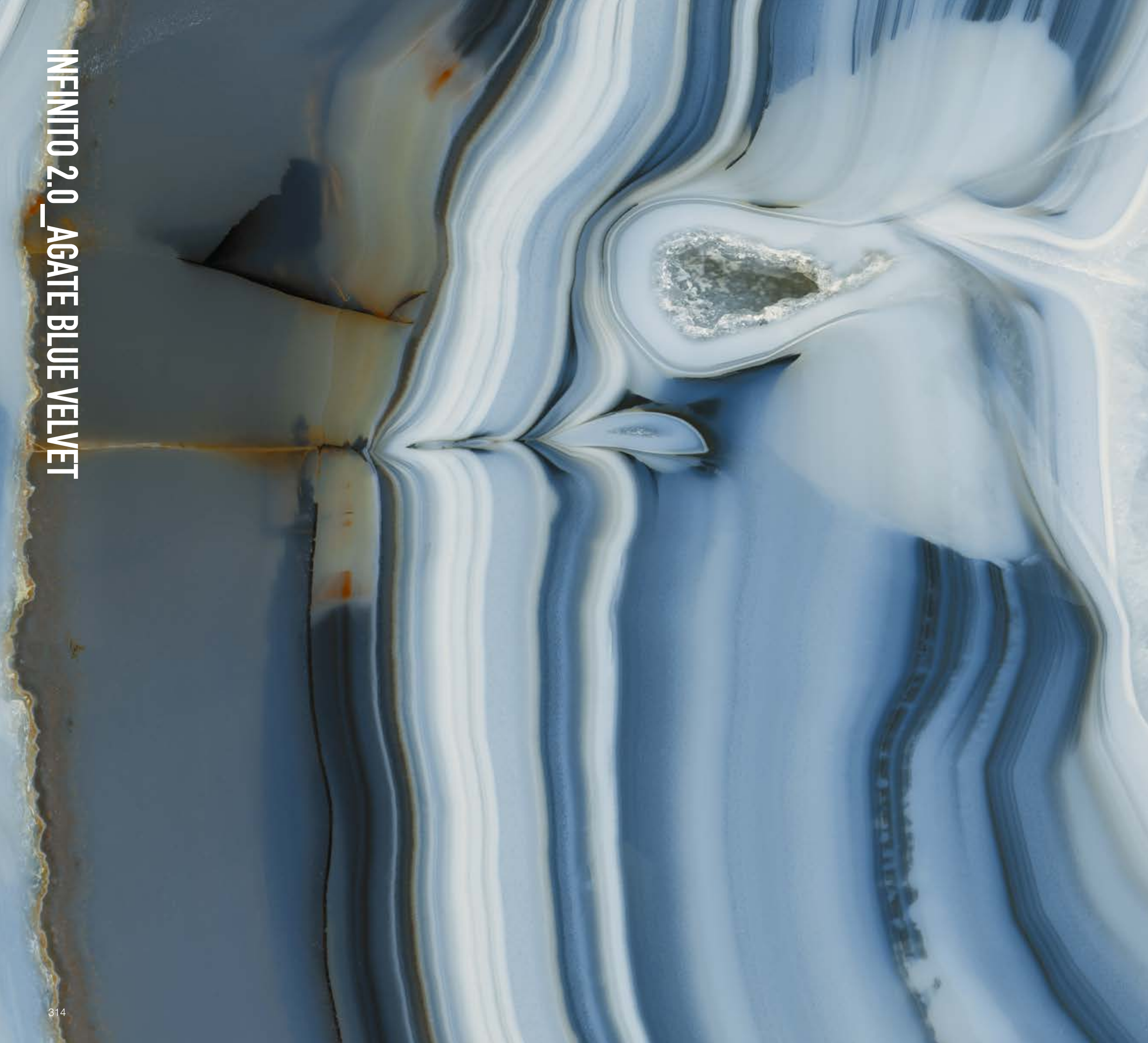

INF2433 Agate Blue Velvet *polished\_A*

INF2434 Agate Blue Velvet *polished\_B*

### 1 SURFACE

Polished

L'effetto Bookmatch tra le diverse lastre è soggetto alla tolleranza tipica del prodotto lapideo. The bookmatching effect created by placing different slabs together is subject to the usual joint specifications of stone tiles. | L'effet Bookmatch entre différentes dalles est soumis à la tolérance typique du produit en pierre. | El efecto Bookmatch entre diferentes losas está sujeto a la tolerancia propia del producto pétreo. | Der Effekt des Bookmatching zwischen den verschiedenen Platten unterliegt der typischen Toleranz des Produktes aus Stein.

**163x324**

64,17"x127,56"

**12 mm**

Impasto: Bianco  
Body: White

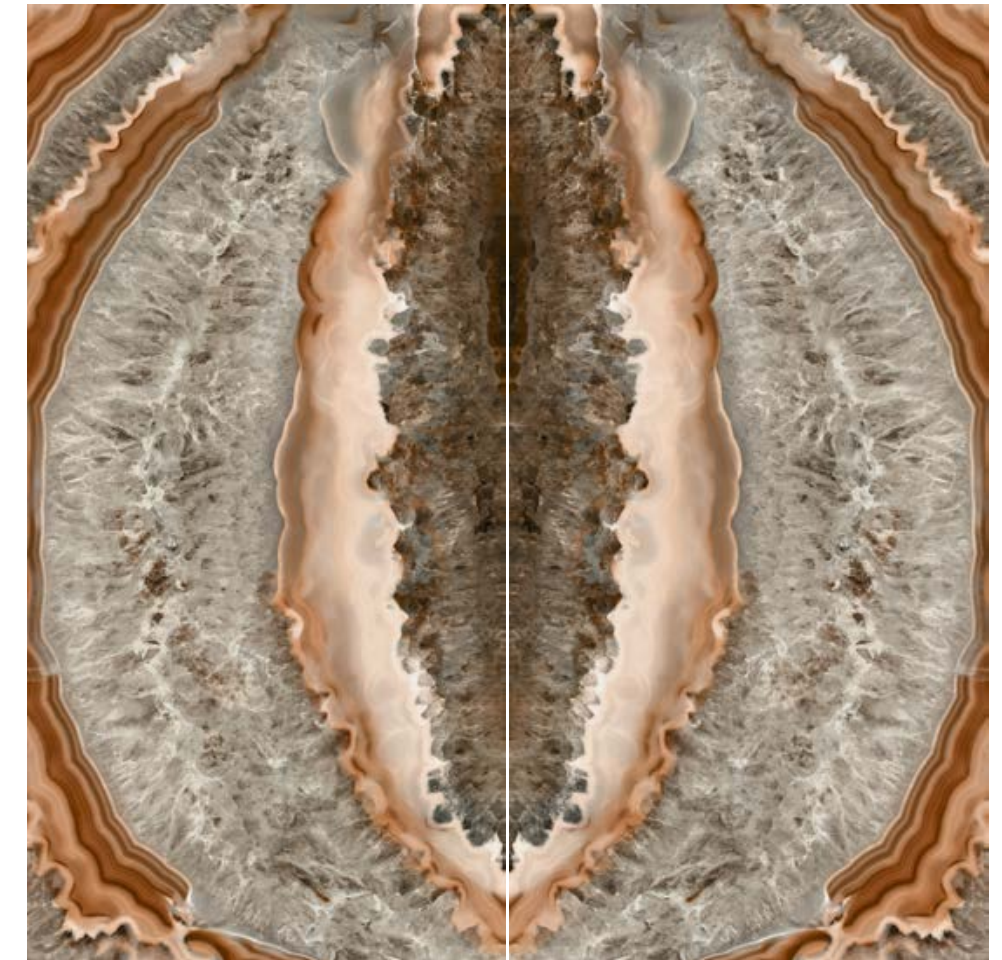
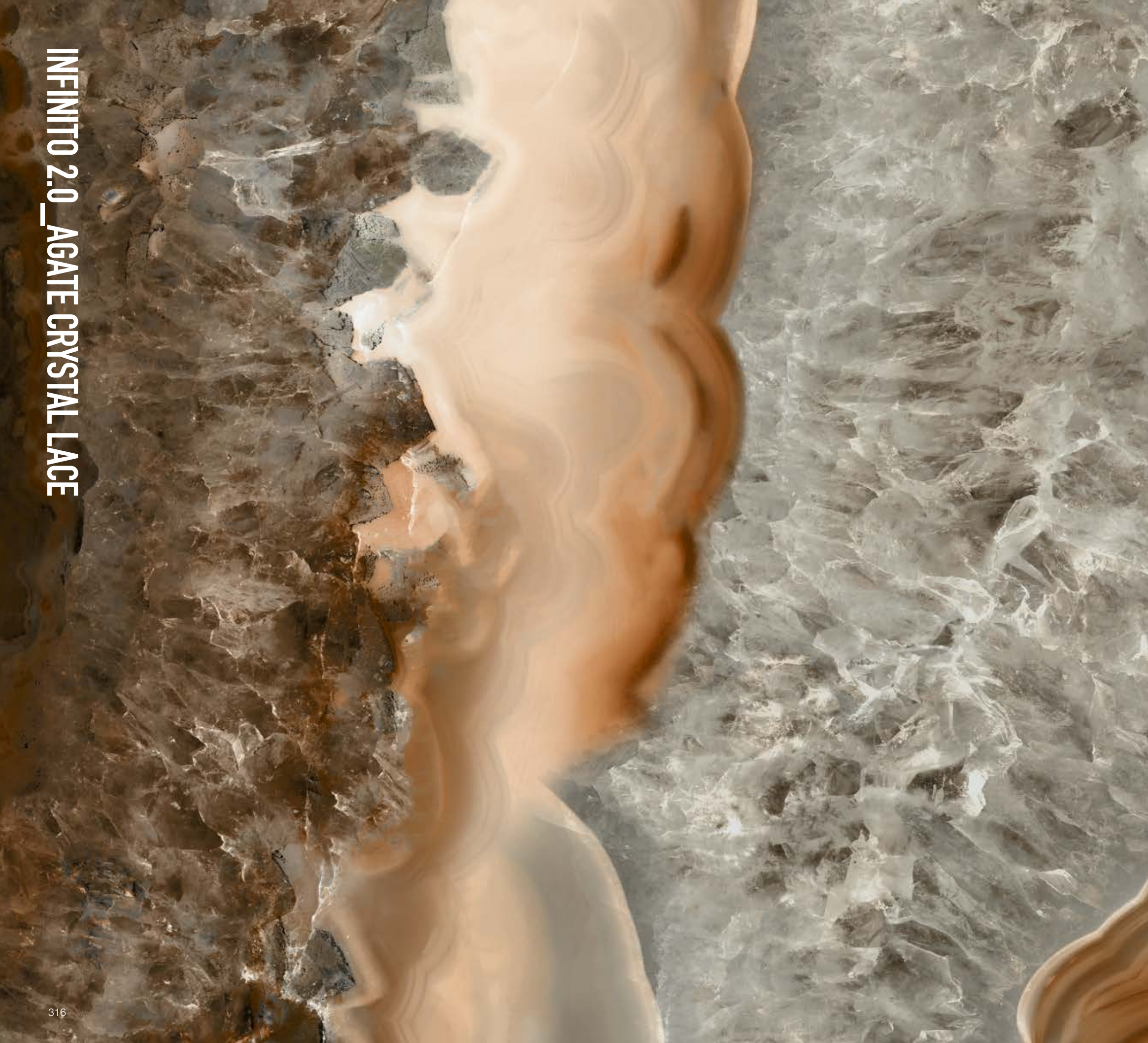

INF2437 Agate Crystal Lace *polished\_A*

INF2438 Agate Crystal Lace *polished\_B*

### 1 SURFACE

Polished

L'effetto Bookmatch tra le diverse lastre è soggetto alla tolleranza tipica del prodotto lapideo. The bookmatching effect created by placing different slabs together is subject to the usual joint specifications of stone tiles. | L'effet Bookmatch entre différentes dalles est soumis à la tolérance typique du produit en pierre. | El efecto Bookmatch entre diferentes losas está sujeto a la tolerancia propia del producto pétreo. | Der Effekt des Bookmatching zwischen den verschiedenen Platten unterliegt der typischen Toleranz des Produktes aus Stein.

**163x324**

64,17"x127,56"

**12 mm**

Impasto: Grigio  
Body: Grey

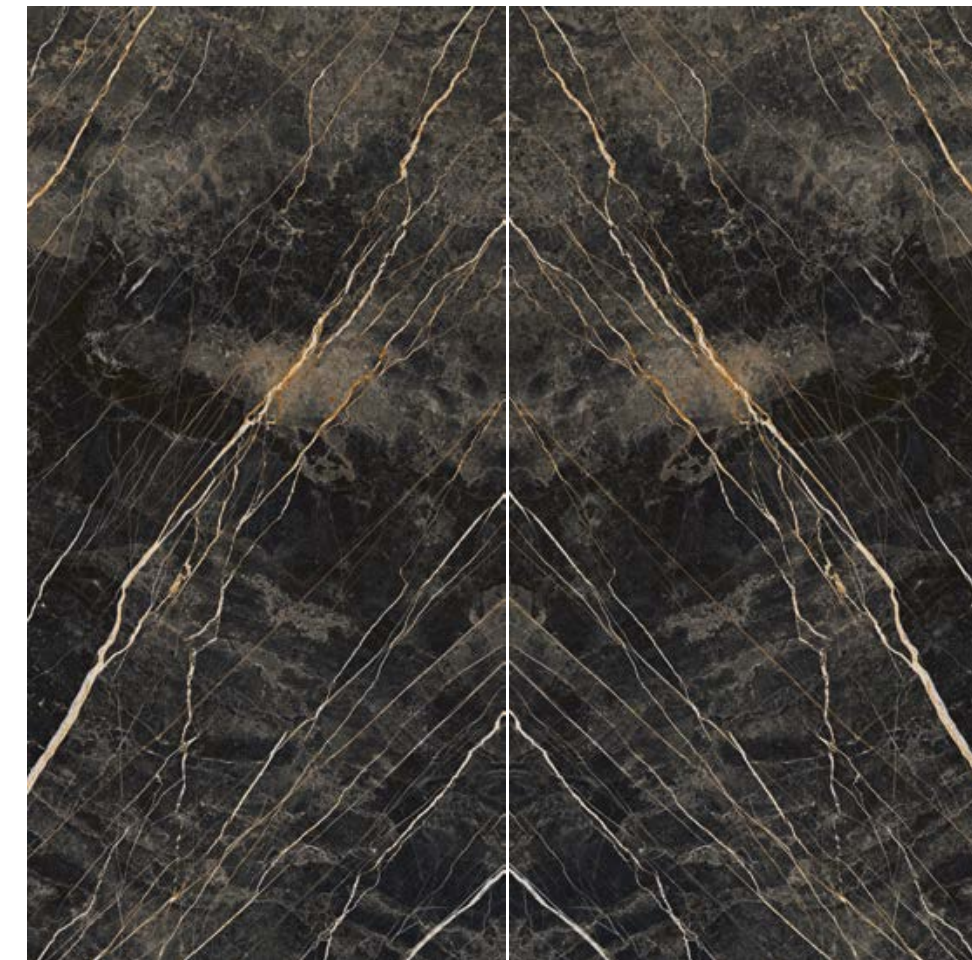

INF2173 Port Laurent *polished\_A*

INF2174 Port Laurent *polished\_B*

## 1 SURFACE

Polished

L'effetto Bookmatch tra le diverse lastre è soggetto alla tolleranza tipica del prodotto lapideo.  
The bookmatching effect created by placing different slabs together is subject to the usual joint specifications of stone tiles. | L'effet Bookmatch entre différentes dalles est soumis à la tolérance typique du produit en pierre. | El efecto Bookmatch entre diferentes losas está sujeto a la tolerancia propia del producto pétreo. | Der Effekt des Bookmatching zwischen den verschiedenen Platten unterliegt der typischen Toleranz des Produktes aus Stein.

**163x324**

64,17"x127,56"

**12 mm**

Impasto: Nero  
Body: Black

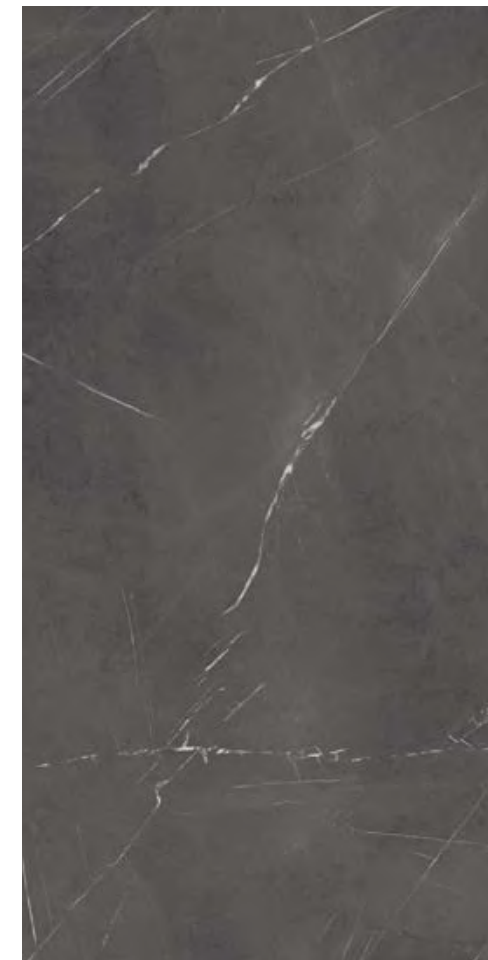

INF2260 Pietra Grey *natural*  
INF2386 Pietra Grey *polished*

**2 SURFACES**

Polished | Natural

**163x324**

64,17"x127,56"

**12 mm**

Impasto: Nero  
Body: Black

INFINITO 2.0\_BLACK PEARL



INF2867 Black Pearl *natural*

**1 SURFACE**  
Natural

**163x324**  
64,17"x127,56"

**12 mm**

Impasto: Nero  
Body: Black



INF482 Sahara Noir *honed*  
INF483 Sahara Noir *polished*

**2 SURFACES**

Honed | Polished

**163x324**

64,17"x127,56"

**12 mm**

Impasto: Nero  
Body: Black

La superficie HONED è una finitura di nuova concezione che risulta più opaca rispetto alla versione POLISHED. Le differenze di lucentezza ed eventuali disomogeneità di aspetto sono quindi da considerare caratteristiche intrinseche di questa superficie.

The HONED surface is a new finish that gives a more matt effect than the POLISHED version. Any differences in shine and appearance are therefore a natural feature of this surface finish.



STL225 Nebula Grey Full 3D texture\_A

STL228 Nebula Grey Full 3D texture\_B

**1 SURFACE**

Full 3D Texture

**163x324**

64,17"x127,56"

**12 mm**

**Impasto: Grigio**  
Body: Grey

L'effetto Bookmatch tra le diverse lastre è soggetto alla tolleranza tipica del prodotto lapideo. The bookmatching effect created by placing different slabs together is subject to the usual joint specifications of stone tiles. | L'effet Bookmatch entre différentes dalles est soumis à la tolérance typique du produit en pierre. | El efecto Bookmatch entre diferentes losas está sujeto a la tolerancia propia del producto pétreo. | Der Effekt des Bookmatching zwischen den verschiedenen Platten unterliegt der typischen Toleranz des Produktes aus Stein.



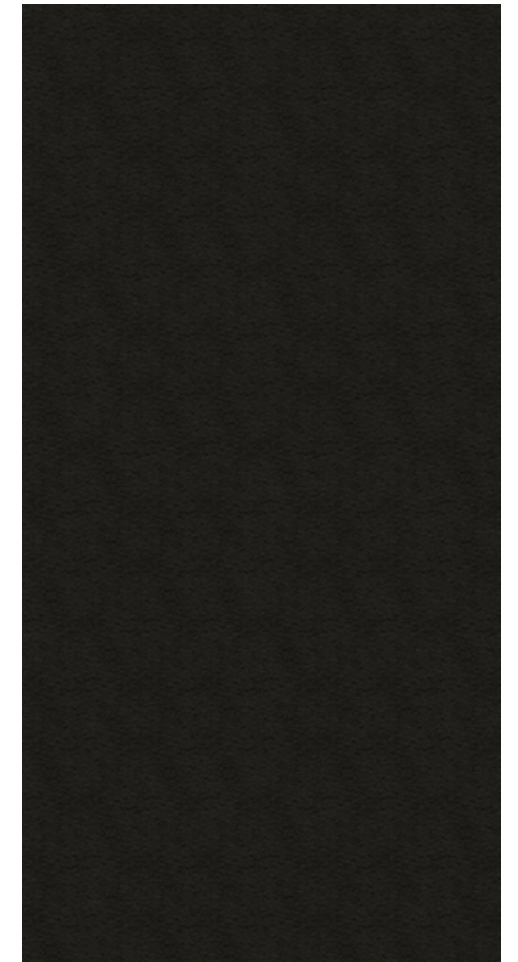

STL137 Nero Zimbabwe *Full 3D texture*

**1 SURFACE**  
Full 3D texture

**163x324**  
64,17"x127,56"

**12 mm**

Impasto: Nero  
Body: Black



STL144 Negresco 3D texture real matt\_A

STL145 Negresco 3D texture real matt\_B

### 1 SURFACE

3D Texture Real Matt

**163x324**

64,17"x127,56"

**12 mm**

**Impasto: Nero**  
Body: Black

L'effetto Bookmatch tra le diverse lastre è soggetto alla tolleranza tipica del prodotto lapideo.  
The bookmatching effect created by placing different slabs together is subject to the usual joint specifications of stone tiles. | L'effet Bookmatch entre différentes dalles est soumis à la tolérance typique du produit en pierre. | El efecto Bookmatch entre diferentes losas está sujeto a la tolerancia propia del producto pétreo. | Der Effekt des Bookmatching zwischen den verschiedenen Platten unterliegt der typischen Toleranz des Produktes aus Stein.



STL150 Colorado 3D texture\_A

STL151 Colorado 3D texture\_B

## 1 SURFACE

3D Texture

L'effetto Bookmatch tra le diverse lastre è soggetto alla tolleranza tipica del prodotto lapideo. The bookmatching effect created by placing different slabs together is subject to the usual joint specifications of stone tiles. | L'effet Bookmatch entre différentes dalles est soumis à la tolérance typique du produit en pierre. | El efecto Bookmatch entre diferentes losas está sujeto a la tolerancia propia del producto pétreo. | Der Effekt des Bookmatching zwischen den verschiedenen Platten unterliegt der typischen Toleranz des Produktes aus Stein.

**163x324**

64,17"x127,56"

**12 mm**

**Impasto: Beige**  
Body: Beige



STL267 Travertino Bianco *real matt*  
STL264 Travertino Bianco *full 3D texture honed*

**2 SURFACES** **163x324**  
Real Matt | Full 3D Texture Honed 64,17"x127,56"

**12 mm**  
Impasto: Bianco  
Body: White





STL053 Travertino Ebur *real matt*  
STL208 Travertino Ebur *full 3D texture honed*

**2 SURFACES**  
Real Matt | Full 3D Texture Honed

**163x324**

64,17"x127,56"

**12 mm**

Impasto: Bianco  
Body: White





STL130 Travertino Fuscus *real matt*

STL211 Travertino Fuscus *full 3D texture honed*

**2 SURFACES**

Real Matt | Full 3D Texture Honed 64,17"x127,56"

**163x324**

**12 mm**

Impasto: Beige  
Body: Beige





STL019 Jura White *real matt*

**1 SURFACES**  
Real Matt

**163x324**  
64,17"x127,56"

**12 mm**

Impasto: Bianco  
Body: White

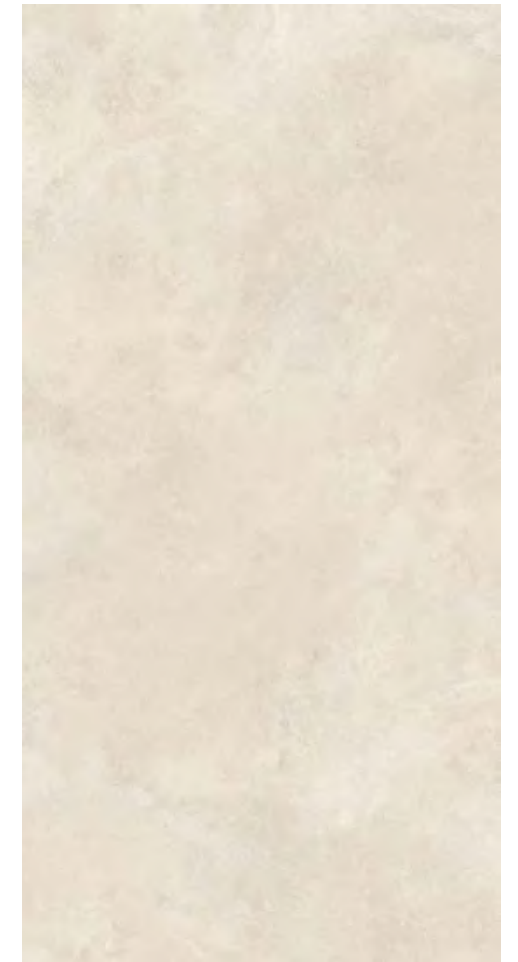

STL021 Chianca *real matt*

**1 SURFACES**  
Real Matt

**163x324**  
64,17"x127,56"

**12 mm**

Impasto: Bianco  
Body: White



STL222 Sikelia *full 3D texture*

**1 SURFACE**  
Full 3D Texture

**163x324**  
64,17"x127,56"

**12 mm**

Impasto: Beige  
Body: Beige



STL121 Ceppo *real matt*  
STL129 Ceppo *full 3D texture*

**2 SURFACES**  
Real Matt | Full 3D Texture

**163x324**  
64,17"x127,56"

**12 mm**  
Impasto: Grigio  
Body: Grey





STL056 Silver Stone *natural\_A*

STL057 Silver Stone *natural\_B*

## 1 SURFACE

Natural

L'effetto Bookmatch tra le diverse lastre è soggetto alla tolleranza tipica del prodotto lapideo.  
The bookmatching effect created by placing different slabs together is subject to the usual joint specifications of stone tiles. | L'effet Bookmatch entre différentes dalles est soumis à la tolérance typique du produit en pierre. | El efecto Bookmatch entre diferentes losas está sujeto a la tolerancia propia del producto pétreo. | Der Effekt des Bookmatching zwischen den verschiedenen Platten unterliegt der typischen Toleranz des Produktes aus Stein.

**163x324**

64,17"x127,56"

**12 mm**

Impasto: Grigio  
Body: Grey

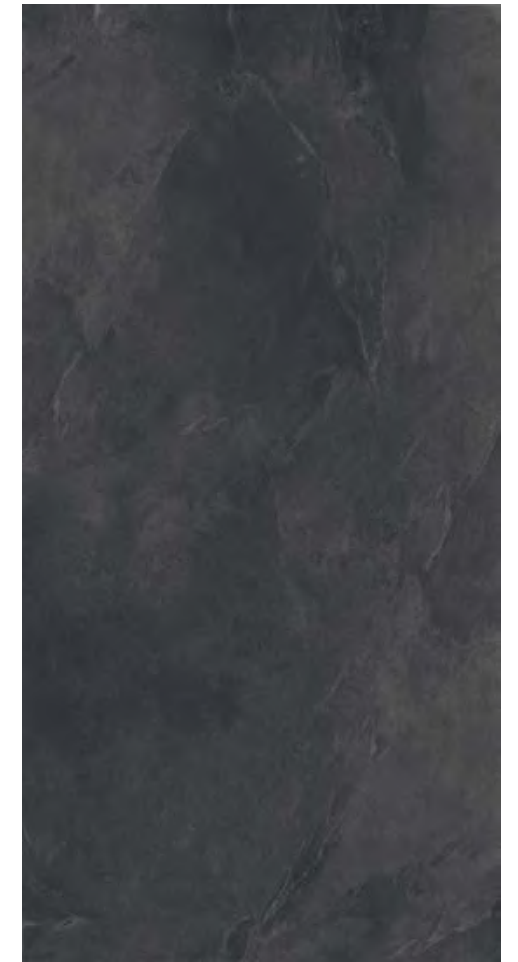

STL020 Slate Black *real matt*

**1 SURFACES**  
Real Matt

**163x324**  
64,17"x127,56"

**12 mm**

Impasto: Nero  
Body: Black

ALPINE LIGHT GREY VEIN



ALP197 Alpine Light Grey Vein 3D texture

**1 SURFACES**  
3D Texture

**163x324**  
64,17"x127,56"

**12 mm**

Impasto: Beige  
Body: Beige





PNT311 Venus *natural*

**1 SURFACE**  
Natural

**163x324**  
64,17"x127,56"

**12 mm**

Impasto: Bianco  
Body: White



PNT314 Jupiter *natural*

**1 SURFACE**  
Natural

**163x324**  
64,17"x127,56"

**12 mm**

Impasto: Nero  
Body: Black



PNT323 Pluto *natural*

**1 SURFACE**  
Natural

**163x324**  
64,17"x127,56"

**12 mm**

Impasto: Nero  
Body: Black



PTL137 Jordan *natural*

**1 SURFACE**  
Natural

**163x324**  
64,17"x127,56"

**12 mm**

Impasto: Bianco  
Body: White



PTL138 Hood *natural*

**1 SURFACE**  
Natural

**163x324**  
64,17"x127,56"

**12 mm**

Impasto: Grigio  
Body: Grey



PTL139 Tabor *natural*

**1 SURFACE**  
Natural

**163x324**  
64,17"x127,56"

**12 mm**

Impasto: Nero  
Body: Black



KOM170 Elegant *natural*

**1 SURFACE**  
Natural

**163x324**  
64,17"x127,56"

**12 mm**

Impasto: Beige  
Body: Beige



KOM171 Original *natural*

**1 SURFACE**  
Natural

**163x324**  
64,17"x127,56"

**12 mm**

Impasto: Beige  
Body: Beige

criteri di 1° scelta | first class  
 criteria | critères de premier choix  
 | criterios de 1ª elección | Kriterien  
 für die 1. Wahl

**White Natural**

Puntini a contrasto: fino a 5 puntini di dimensioni inferiori a 1 mm e posizionati lontani tra loro almeno 1,5 metri | Contrast spots: up to 5 spots less than 1mm in size and positioned at least 1.5 meters away from each other | Points contrastés : jusqu'à 5 points d'une taille inférieure à 1 mm et placés à une distance d'au moins 1,5 mètre les uns des autres | Puntos de contraste: hasta 5 puntos de menos de 1 mm de tamaño y colocados a una distancia mínima de 1,5 metros. | Kontrastpunkte: bis zu 5 Pünktchen mit einer Größe von weniger als 1 mm und einem Abstand von mindestens 1,5 m zueinander

Fori e spillature: fino a 3 buchi piccoli (si intende spillature di diametro inferiore a 0,3 mm) sparsi, quindi lontani fra loro almeno 1,5 metri | Holes and pin-holes: up to 3 small holes (meaning pin-holes with a diameter of less than 0,3 mm) scattered, therefore at least 1,5 meters away from each other | Trous et trous d'épingle: jusqu'à 3 petits trous (c'est-à-dire des trous d'épingle d'un diamètre inférieur à 0,3 mm) épars, c'est-à-dire espacés d'au moins 1,5 mètre | Agujeros y grapas: hasta 3 pequeños agujeros (es decir, grapas de menos de 0,3 mm de diámetro) dispersos y, por tanto, separados entre sí al menos 1,5 metros | Löcher und Nadellöcher: bis zu 3 kleine verstreute Löcher (darunter werden Nadellöcher mit einem Durchmesser von weniger als 0,3 mm verstanden), daher mindestens 1,5 m voneinander entfernt

Fino a un solo foro di dimensioni inferiori a 1 mm | Up to a single hole less than 1mm in size | Jusqu'à un seul trou d'une taille inférieure à 1 mm | Hasta un único orificio de menos de 1 mm de tamaño | Bis zu einem einzelnen Loch mit einer Größe von weniger als 1 mm

**White Polished**

Assenza di graffi da mola, alonature da trattamento e segni di avanzamento | Absence of grindstone scratches, processing halos and feed marks | Absence de rayures réalisées par la meule, d'auréoles dues au traitement et de signes d'avancement | Ausencia de arañazos de la muela, halos de tratamiento y marcas de progreso | Keine Kratzer durch Schleifsteine, Ränder durch Behandlung und Vorschubzeichen

Puntini a contrasto: fino a 5 puntini di dimensioni inferiori a 1 mm e posizionati lontani tra loro almeno 1,5 metri | Contrast spots: up to 5 spots less than 1mm in size and positioned at least 1.5 meters away from each other | Points contrastés : jusqu'à 5 points d'une taille inférieure à 1 mm et placés à une distance d'au moins 1,5 mètre les uns des autres | Puntos de contraste: hasta 5 puntos de menos de 1 mm de tamaño y colocados a una distancia mínima de 1,5 metros. | Kontrastpunkte: bis zu 5 Pünktchen mit einer Größe von weniger als 1 mm und einem Abstand von mindestens 1,5 m zueinander

Spillature: fino a due di dimensioni inferiori a 0,2 mm, sparse, quindi lontani fra loro almeno 1,5 metri | Pin-holes: up to two less than 0.2 mm in size, scattered, therefore at least 1.5 meters away from each other | Trous d'épingle: jusqu'à deux d'une taille inférieure à 0,2 mm, épars, c'est-à-dire espacés d'au moins 1,5 mètre | Alfileres: hasta dos más pequeños de 0,2 mm, dispersos, por lo tanto a una distancia mínima de 1,5 metros. | Nadellöcher: bis zu zwei verstreute Punkte mit einer Größe von weniger als 0,2 mm und daher mindestens 1,5 m voneinander entfernt

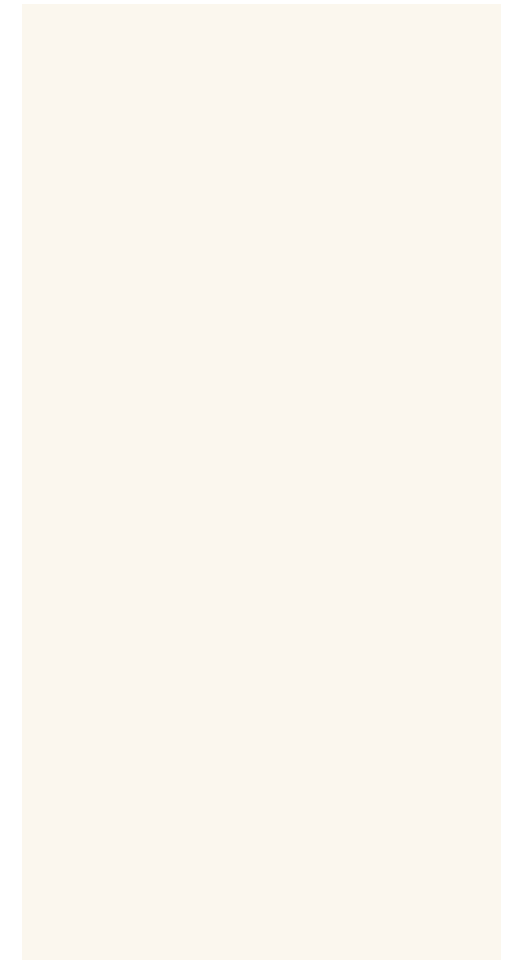

MNC020 White *polished\_12mm*  
 MNC014 White *natural\_12mm*

**2 SURFACES**

Natural | Polished

**163x324**

64,17"x127,56"

**12 mm**

Impasto: Bianco  
 Body: White

criteri di 1° scelta | first class  
criteria | critères de premier choix  
| criterios de 1ª elección | Kriterien  
für die 1. Wahl

### Black Natural

Puntini a contrasto: fino a 5 puntini di dimensioni inferiori a 1 mm e posizionati lontani tra loro almeno 1,5 metri | Contrast spots: up to 5 spots less than 1mm in size and positioned at least 1.5 meters away from each other | Points contrastés : jusqu'à 5 points d'une taille inférieure à 1 mm et placés à une distance d'au moins 1,5 mètre les uns des autres | Puntos de contraste: hasta 5 puntos de menos de 1 mm de tamaño y colocados a una distancia mínima de 1,5 metros. | Kontrastpunkte: bis zu 5 Punkten mit einer Größe von weniger als 1 mm und einem Abstand von mindestens 1,5 m zueinander

Fori e spillature: fino a 3 buchi piccoli (si intende spillature di diametro inferiore a 0,3 mm) sparsi, quindi lontani fra loro almeno 1,5 metri | Holes and pin-holes: up to 3 small holes (meaning pin-holes with a diameter of less than 0.3 mm) scattered, therefore at least 1.5 meters away from each other | Troues et trous d'épingle: jusqu'à 3 petits trous (c'est-à-dire des trous d'épingle d'un diamètre inférieur à 0,3 mm) épars, c'est-à-dire espacés d'au moins 1,5 mètre | Agujeros y grapas: hasta 3 pequeños agujeros (es decir, grapas de menos de 0,3 mm de diámetro) dispersos y, por tanto, separados entre sí al menos 1,5 metros | Löcher und Nadellöcher: bis zu 3 kleine verstreute Löcher (darunter werden Nadellöcher mit einem Durchmesser von weniger als 0,3 mm verstanden), daher mindestens 1,5 m voneinander entfernt

Fino a un solo foro di dimensioni inferiori a 1 mm | Up to a single hole less than 1mm in size | Jusqu'à un seul trou d'une taille inférieure à 1 mm | Hasta un único orificio de menos de 1 mm de tamaño | Bis zu einem einzelnen Loch mit einer Größe von weniger als 1 mm



MNC018 Black *natural\_12mm*

## 1 SURFACE

Natural

163x324

64,17"x127,56"

12 mm

Impasto: Nero  
Body: Black

Effetto Marmo | Marble Effect  
**INFINITO 2.0**

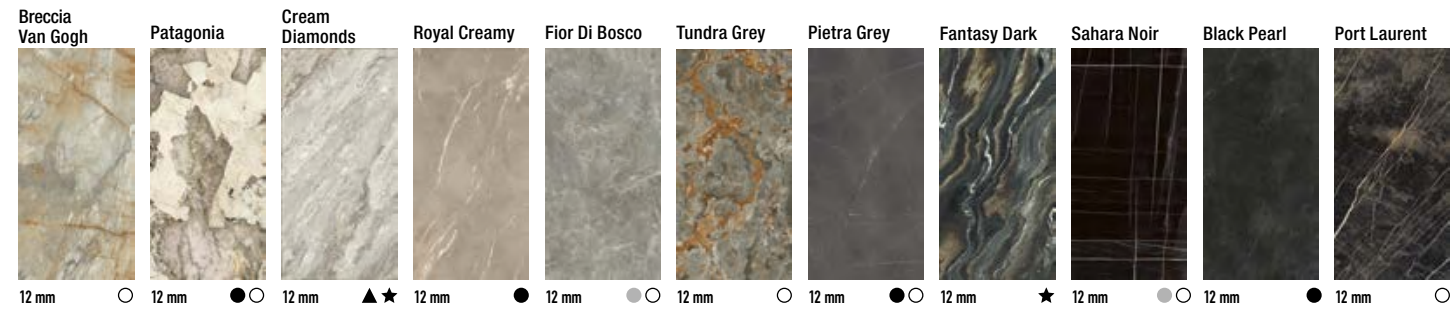
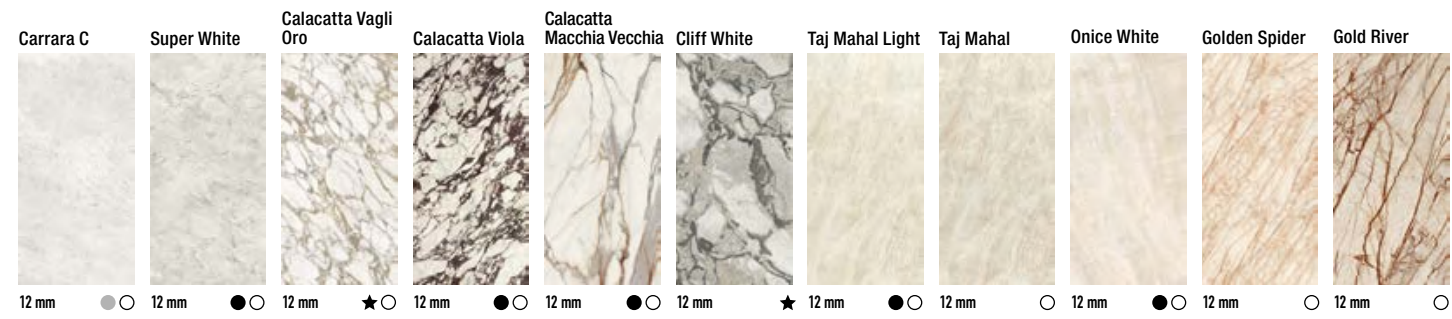
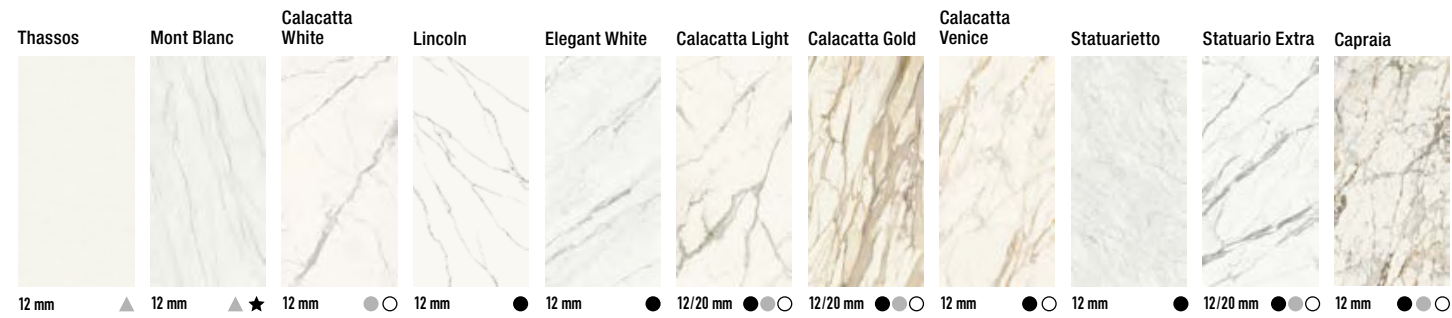

Effetto Pietra | Stone Effect  
**STONE LAB**

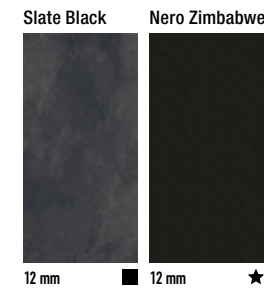
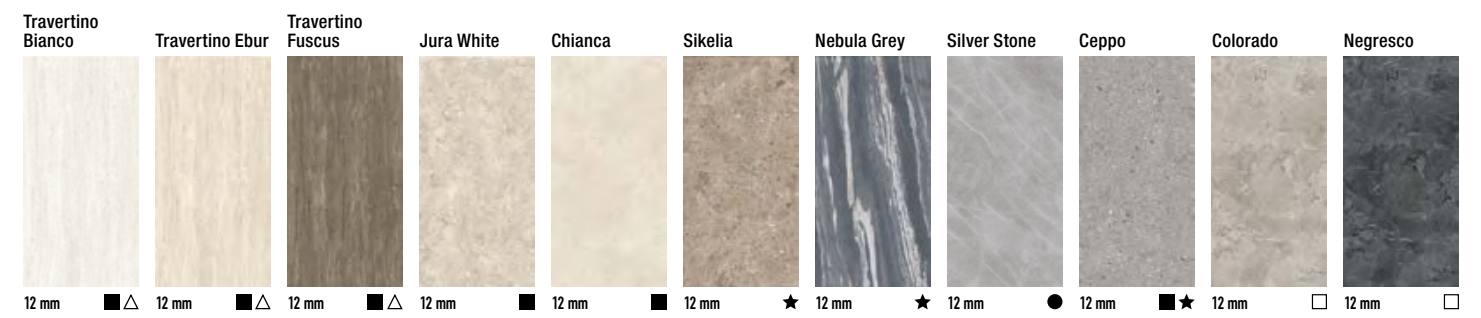

Effetto Cemento | Concrete Effect  
**PORTLAND**

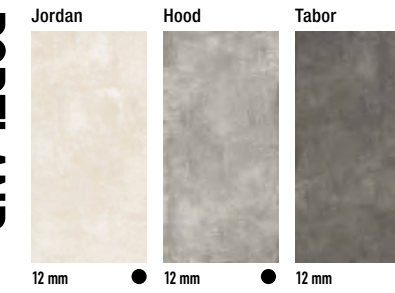

Effetto Legno | Wood Effect  
**KOMI**



Effetto Pietra | Stone Effect  
**PLANETO**

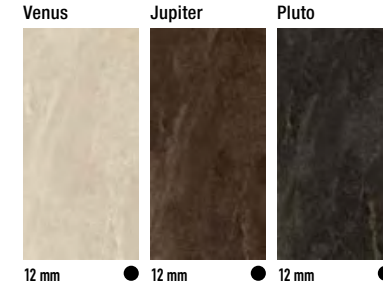

Effetto Pietra | Stone Effect  
**ALPINE**



Effetto Monocromatico | Monochromatic Effect  
**MONOCHROME**

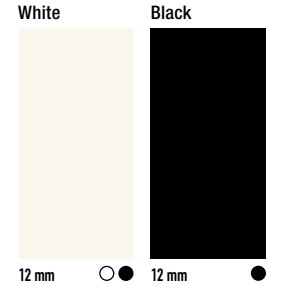

**SURFACES**

- Natural
- Honed
- Polished
- ▲ Crystal Polished
- ◆ ALL-LIGHT Polished
- Real Matt
- 3D Texture
- ▲ Full 3D Texture Polished
- △ Full 3D Texture Honed
- ★ Full 3D Texture

Tutte le lastre Mytop in 12 e 20 mm sono rinforzate strutturalmente con una stuoia in fibra di vetro applicata sul retro con apposito collante.

All the 12 mm and 20 mm thick MyTop slabs are structurally reinforced with a fibreglass mesh applied to the rear with a specific adhesive.

Toutes les dalles MyTop de 12 mm et 20 mm sont renforcées structurellement par un filet en fibre de verre appliqué au dos avec une colle spéciale.

Todas las placas Mytop en 12 y 20 mm están reforzadas estructuralmente con una malla de fibra de vidrio aplicada en la parte posterior con un adhesivo especial.

Alle Platten aus der Kollektion MyTop in der Materialstärke 12 mm und 20 mm sind mit Glasfasergewebe bewehrt, das mit Spezialklebstoff auf die Rückseite geklebt ist.

---

## TECH INFO

CARATTERISTICHE TECNICHE

# CERTIFICAZIONI

Certifications | Certifications | Certificaciones | Zertifizierungen

### Certificazioni ambientali

Environmental Certifications | Certifications Environnementales | Certificaciones medioambientales | Zertifizierungen Umwelt

## Certificazioni ISO 9001:2015

ISO 9001:2015 certification | certification ISO 9001:2015 | certificación ISO 9001:2015 | zertifizierung ISO 9001:2015

La Certificazione ISO 9001:2015 sviluppata dall'Organizzazione Internazionale per la Standardizzazione (ISO o International Organization for Standardization), fornisce linee guida e norme utili nel raggiungimento di standard universalmente riconosciuti, in un’ottica di miglioramento continuo dei processi. | ISO 9001:2015, developed by the International Organization for Standardization, provides guidelines and rules for the establishment of universally recognised standards, with a view to achieving continuous process improvement. | La Certification ISO:9001:2015, élaborée par l’Organisation Internationale de Normalisation (ISO), fournit des lignes directrices et des règles utiles pour atteindre des normes universellement reconnues, dans une optique d’amélioration continue des processus. | La certificación ISO 9001:2015, desarrollada por la Organización Internacional de Normalización (ISO), proporciona directrices y normas útiles para alcanzar estándares universalmente reconocidos, con vistas a la mejora continua de los procesos. | Die ISO-Zertifizierung: 9001:2015, entwickelt von der Internationalen Organisation für Standardisierung (ISO oder International Organization for Standardization), liefert Richtlinien und Standards, die zur Erreichung allgemein anerkannte Standards im Hinblick auf eine kontinuierliche Prozessverbesserung nützlich sind.



### EMAS

### (Eco-Management and Audit Scheme)

È un sistema comunitario di ecogestione e audit creato dalla Comunità Europea, a cui possono aderire volontariamente le imprese che desiderano impegnarsi nel valutare e migliorare la propria efficienza ambientale, fornendo alle organizzazioni e ad altri soggetti informazioni sulle proprie prestazioni. L'azienda deve elaborare un proprio sistema di gestione ambientale (SGA) basato sulla norma ISO 14001:2004 e deve rilasciare una Dichiarazione Ambientale pubblica in cui la qualità del prodotto e il processo produttivo risultino conformi a uno sviluppo economico sostenibile. | This EU-created eco-management and audit scheme is open, voluntarily, to any companies wishing to commit to assessing and improving their environmental efficiency; once they have joined, the scheme provides organisations and any other parties seeking information with details of their performance. The company must develop its own environmental management system (EMS) based on ISO standard 14001:2004 and must issue a public environmental declaration, stating that the quality of the product and the production process comply with sustainable economic development. | Il s’agit d’un système communautaire de gestion environnemental et d’audit créé par la Communauté européenne, auquel peuvent adhérer volontairement les entreprises qui souhaitent s’engager à évaluer et à améliorer leur efficacité environnementale, en fournissant aux organisations et à d’autres parties prenantes des informations sur leurs performances. L’entreprise doit élaborer son propre système de gestion environnementale (SGE) basé sur la norme ISO 14001:2004 et doit publier une Déclaration Environnementale publique dans laquelle la qualité du produit et le processus de production sont conformes à un développement économique durable. | Es un sistema comunitario de gestión y auditoría medioambientales creado por la Comunidad Europea, al que pueden adherirse voluntariamente las empresas que deseen comprometerse a evaluar y mejorar su propia eficiencia medioambiental, proporcionando a las organizaciones y a otros actores información sobre su rendimiento. La empresa debe elaborar su propio sistema de gestión medioambiental (SGA) basado en la norma ISO 14001:2004 y debe emitir una Declaración Medioambiental pública en la cual la calidad del producto y el proceso de producción consten como conformes con un desarrollo económico sostenible. | Dabei handelt es sich um ein von der Europäischen Gemeinschaft geschaffenes gemeinschaftliches Umweltmanagement- und Auditsystem, dem Unternehmen, die sich zur Bewertung und Verbesserung ihrer Umwelteffizienz verpflichten möchten, freiwillig beitreten können und Organisationen und anderen Akteuren Informationen über ihre Leistung liefern. Das Unternehmen muss ein eigenes Umwelt-Managementsystem (EMS) auf Basis der Norm ISO 14001:2004 entwickeln und eine öffentliche Umwelterklärung ausstellen, in der die Qualität des Produkts und des Produktionsprozesses einer nachhaltigen wirtschaftlichen Entwicklung entsprechen.



### emissioni di COV nell'atmosfera

Emissions into the atmosphere | émission dans l'air intérieur | Emisiones de COV en la atmósfera | Emissionen in die Atmosphäre

Tutte le collezioni di Ceramica Fondovalle hanno ottenuto A+ | All Ceramica Fondovalle’s collections have obtained A+ | Toutes les collections de Ceramica Fondovalle ont obtenu A+ | Todas las colecciones de Ceramica Fondovalle han obtenido la calificación A+ | Alle Kollektionen von Ceramica Fondovalle haben A+ erhalten



### UNI EN ISO 14001:2015

### sistema di gestione ambientale

Environmental management system | Système de gestion environnementale | Sistema de gestión medioambiental | Umwelt-Managementsystem

La certificazione ISO 14001 attesta i requisiti di un sistema di gestione ambientale adeguato che l'azienda utilizza in modo sistematico per migliorare le proprie prestazioni e ridurre gli impatti ambientali della propria attività. | ISO 14001 certification demonstrates that the company adopts an appropriate environmental management system to improve its performance and reduce the environmental impacts of its business. | La certification ISO 14001 atteste des exigences d’un système de management environnemental adéquat que l’entreprise utilise systématiquement pour améliorer ses performances et réduire les impacts environnementaux de son activité. | La certificación ISO 14001 acredita los requisitos de un adecuado sistema de gestión medioambiental que la empresa utiliza de forma sistemática para mejorar su rendimiento y reducir los impactos medioambientales de su actividad. | Die Zertifizierung ISO 14001 bescheinigt die Anforderungen an ein angemessenes Umwelt-Managementsystem, das das Unternehmen systematisch anwendet, um seine Leistung zu verbessern und die Umweltauswirkungen seiner Tätigkeit zu reduzieren.



### Good Phytosanitary Practices

I marchi commerciali di Italcer sono inseriti nel Registro delle Aziende Qualificate per il rispetto delle Linee Guida del programma “Good Phytosanitary Practices (GPP)”, uno standard finalizzato al miglioramento delle pratiche fitosanitarie per procedure di spedizione di container verso gli Stati Uniti. | Italcer’s trademarks are included in the Register of Qualified Companies for ensuring compliance with the Guidelines of the “Good Phytosanitary Practices (GPP)” program, a Standard aimed at improving phytosanitary practices for container shipping procedures to the United States. | Ceramica Rondine, with a view to facilitating deliveries to the United States, has adhered to the guidelines of the Good Phytosanitary Practices programme of the Certiquality Inspection Body. This is a specific, relevant move that places Ceramica Rondine on the Register of Qualified Companies, and is an important step towards improving deliveries towards the USA and the timescales required. | Les marques commerciales d’Italcer figurent dans le registre des entreprises soumises au respect des directives du programme « Good Phytosanitary Practices (GPP) », une norme visant à améliorer les pratiques phytosanitaires dans le cadre des procédures d’expédition de containers vers les États-Unis. | Las marcas comerciales de Italcer están inscritas en el Registro de Empresas Cualificadas por cumplir las Directrices del programa «Good Phytosanitary Practices (GPP)», una norma destinada a mejorar las prácticas fitosanitarias para los procedimientos de envío de contenedores a los Estados Unidos. | Die Marken von Italcer sind im Verzeichnis qualifizierter Unternehmen für die Einhaltung der Leitlinien der des Programms „Good Phytosanitary Practices (GPP)“ eingetragen. Dieser Standard bezweckt die Verbesserung der Pflanzenschutzpraxis bei Containerversandverfahren in die Vereinigten Staaten.

### Certificazioni di prodotto

Product Certifications | Certifications Du Produit | Certificaciones de producto | Produktzertifizierungen



### marcatura CE

CE Mark | Marquage CE | Marquage CE | Marcado CE | CE-Kennzeichnung

La marcatura CE garantisce la conformità di prodotto ai requisiti essenziali in ordine alla sicurezza del prodotto e alla salute dell'utilizzatore. | The CE mark guarantees product compliance with the essential requirements concerning product safety and user health. | Le marquage CE garantit la conformité du produit aux exigences essentielles concernant la sécurité du produit et la santé de l'utilisateur. | El marcado CE garantiza la conformidad del producto con los requisitos esenciales en materia de seguridad del producto y salud del usuario. | Die CE-Kennzeichnung garantiert die Konformität des Produktes mit den grundlegenden Anforderungen an die Produktsicherheit und die Gesundheit des Anwenders.



### dichiarazione MOCA

Declaration of compliance for FCMs | Déclaration MOCA | Declaración MOCA | Erklärung MOCA

La Dichiarazione di Conformità per i MOCA (Materiali e Oggetti a Contatto con Alimenti) è il documento che garantisce il rispetto delle disposizioni del regolamento 1935/2004/CE per tutti i prodotti destinati a venire a contatto con gli alimenti ed ha lo scopo di attestare che vengano rispettate caratteristiche obbligatorie nell’ambito della sicurezza igienico-sanitaria. | The declaration of compliance for FCMs (Food Contact Materials) is the document that guarantees compliance with the provisions of EU Regulation 1935/2004/EC for all products intended to come into contact with food. Its purpose is to certify that specific requirements in the field of health and hygiene safety are met. | La Déclaration de Conformité pour les MOCA (Matériaux et Objets en Contact avec les Aliments) est le document qui garantit le respect des dispositions du règlement 1935/2004/CE pour tous les produits destinés à entrer en contact avec les aliments et vise à attester que les caractéristiques obligatoires sont respectées dans le domaine de la sécurité hygiénique et sanitaire. | La Declaración de Conformidad para los MOCA (Materiales y Objetos en Contacto con Alimentos) es el documento que garantiza el cumplimiento de las disposiciones del Reglamento 1935/2004/CE para todos los productos destinados a entrar en contacto con alimentos y tiene por objeto certificar que se respetan las características obligatorias en materia de seguridad higiénico-sanitaria. | Die Konformitätserklärung für MOCA (Materialien und Gegenstände im Kontakt zu Lebensmitteln) ist das Dokument, das die Einhaltung der Bestimmungen der Verordnung 1935/2004/EG für alle Produkte garantiert, die dazu bestimmt sind, mit Lebensmitteln in Kontakt zu gelangen, und die Aufgabe hat, zu bescheinigen, dass diese obligatorischen Eigenschaften im Bereich Gesundheit und Hygiene eingehalten werden.



### SASO - certificazione SQM

SASO - SQM Certification | SASO - Certification SQM | SASO Certificación SQM | SASO - Zertifizierung SQM

Certificazione di qualità SQM (Saso Quality Mark), riconosciuta da ente saudita di certificazione, finalizzata all’esportazione di prodotti in Arabia Saudita, importante sbocco commerciale del Middle-East. | SQM (Saso Quality Mark) quality certification, awarded by a Saudi certification body for the purposes of exporting products to Saudi Arabia, which is a significant market in the Middle-East. | Certification de qualité SQM (Saso Quality Mark), reconnue par l’organisme de certification saoudien, pour l’exportation de produits vers l’Arabie Saoudite, un important débouché commercial au Moyen-Orient. | Certificación de calidad SQM (Saso Quality Mark), reconocida por un organismo saudí de certificación, destinada a la exportación de productos a Arabia Saudí, importante mercado comercial de Oriente Medio. | SQM-Qualitätszertifizierung (Saso Quality Mark), die von einer saudischen Zertifizierungsstelle anerkannt wird und auf den Export von Produkten nach Saudi-Arabien abzielt, einem wichtigen Handelsplatz im Nahen Osten.



放射性水平：A 类

CHINA  
COMPULSORY  
CERTIFICATE

### certificazione CCC

CCC Certification | Certification CCC | Certificación CCC | CCC-Zertifizierung

Il Certificato Cinese Obbligatorio, conosciuto con l'acronimo CCC (China Compulsory Certification) è un marchio di sicurezza necessario per molti prodotti che accedono al mercato cinese e garantisce un basso contenuto di radio isotopi delle materie prime. | The China Compulsory Certificate (known by the acronym ‘CCC’) is a safety mark which is required for many products entering the Chinese market and which guarantees that the raw materials used have a low radioisotope content. | La Certification Obligatoire Chinoise, connue sous l’acronyme CCC (China Compulsory Certification), est un label de sécurité requis pour de nombreux produits entrant sur le marché chinois et garantissant une faible teneur en radio-isotopes des matières premières. | El Certificado Obligatorio Chino, conocido por las siglas CCC (China Compulsory Certification), es una marca de seguridad necesaria para muchos productos que acceden al mercado chino y garantiza un bajo contenido de radioisótopos en las materias primas. | Die obligatorische chinesische Zertifizierung, bekannt unter dem Akronym CCC (China Compulsory Certification), ist ein notwendiges Sicherheitszeichen für viele Produkte, die auf den chinesischen Markt kommen und garantiert einen niedrigen Radioisotopengehalt der Rohstoffe.



### certificazione ItalyX

ItalyX Certification | Certification ItalyX | Certificación ItalyX | ItalyX-Zertifizierung

Certificazione per le aziende che rappresentano i valori dell’italianità: ricerca della qualità, stile, cura del dettaglio e creatività; favorire lo sviluppo delle filiere produttive italiane e la loro competitività. Promosso da Il Sole 24 Ore in partnership con Confindustria. | Certification for companies that represent the values of being Italian: pursuit of quality, style, attention to detail and creativity; promoting the development of Italian production chains and their competitiveness. Promoted by Il Sole 24 Ore in partnership with Confindustria. | Certification pour les entreprises qui représentent les valeurs de l’italianité : recherche de la qualité, du style, de l’attention aux détails et de la créativité ; promotion du développement des chaînes de production italiennes et de leur compétitivité. Promu par Il Sole 24 Ore en partenariat avec Confindustria. | Certificación para empresas que representan los valores de la italianidad: búsqueda de la calidad, estilo, atención al detalle y creatividad; favorecer el desarrollo de las cadenas de producción italianas y su competitividad. Promovida por Il Sole 24 Ore en colaboración con Confindustria. | Zertifizierung für Unternehmen, die die Werte des Italienischen verkörpern: Streben nach Qualität, Stil, Liebe zum Detail und Kreativität; Förderung der Entwicklung italienischer Produktionsketten und ihrer Wettbewerbsfähigkeit. Gefördert von Il Sole 24 Ore in Partnerschaft mit Confindustria.



Certifications download

# SCHEDE TECNICHE SETTORE ARREDO

Technical specifications furniture industry | Spécifications techniques-secteur ameublement | fichas técnicas del sector del muebl | Technische Datenblätter – Bereich Einrichtung



	Valore Fondovalle Fondovalle values Valeur Fondovalle Valor Fondovalle Fondovalle Werte	Norma / Metodo Norms / Test method Norme / méthode d'essai Norma / Metodo Norm / Methode	
	Natural / Real Matt / 3D Texture 12 mm - 20 mm	Honed / Polished / 3D Texture Honed / 3D Texture Polished / Crystal Polished 12 mm - 20 mm	
<b>Densità</b>   Density   Densité   Densidad   Dichte	2500 kg/m³ valore medio   average value	2500 kg/m³ valore medio   average value	EN 14617-1 ASTM C97
<b>Assorbimento d'acqua</b> Water Absorption   Absorption d'eau   Absorción de agua   Wasseraufnahme	0,1 % valore medio   average value	0,1 % valore medio   average value	EN 14617-1
<b>Resistenza alla flessione</b> Bending strength   Resistance a la flexion   Resistencia a la flexión   Biegezugfestigkeit	50 MPa valore medio   average value	50 MPa valore medio   average value	EN 14617-2
<b>Resistenza al gelo</b> Frost resistance   Résistance au gel   Resistencia al frío   Frostbeständigkeit	Resiste   Resistant	Resiste   Resistant	EN 14617-5
<b>Resistenza al calore secco</b> Dry heat resistance   Résistance à la chaleur   Resistencia al calor seco   Sèche Beständigkeit gegenüber trockener Wärme	5 Nessun effetto visibile fino a 200°C   No visible effect till 200°C	5 Nessun effetto visibile fino a 200°C   No visible effect till 200°C	EN 12722 EN 438-2 par.16
<b>Resistenza all'attacco chimico</b> Chemical resistance Resistance a l'attaque chimique Resistencia al ataque químico Beständigkeit gegen chemikalien	Da classe A a B From class A to B	Da classe A a C From class A to C	ISO 10545-13
	Resiste   Resistant	Resiste (eccetto idrossido di potassio) Resistant (except potassium hydroxide)	ASTM C650
<b>Resistenza ai liquidi freddi</b> Cold liquid resistance   Résistance aux liquides froids   Resistencia a líquidos fríos   Beständigkeit gegenüber kalten Flüssigkeiten	5 Nessun effetto visibile tranne inchiostro (2) No visible effect except ink (2)	Da classe 5 a 2 From class 5 to 2	EN 12720
<b>Resistenza ai prodotti di pulizia</b>   Cleaner product resistance   Résistance aux produits de nettoyage   Resistencia a productos de limpieza   Beständigkeit gegenüber Reinigungsmitteln	5 Nessun effetto visibile No visible effect	Da classe 5 a 3 From class 5 to 3	PTP 53 CATAS
<b>Igiene properties</b> Hygiene properties   Qualités hygiéniques   Propiedades higiénicas   Hygieneeigenschaften	Ottima (grado di rimozione dei batteri >99% dopo pulizia con detergente non battericida) Excellent (high degree of removal of bacterial cells >99% after cleaning with a biocide-free detergent)	Ottima (grado di rimozione dei batteri >99% dopo pulizia con detergente non battericida) Excellent (high degree of removal of bacterial cells >99% after cleaning with a biocide-free detergent)	Metodo CATAS
<b>Resistenza ai funghi</b> Resistance to fungus   Résistance aux champignons   Resistencia a los hongos   Beständigkeit gegenüber Pilzen	Nessuna crescita fungina No fungal growth	Nessuna crescita fungina No fungal growth	ASTM G21
<b>Cessione piombo e cadmio</b>   Lead and cadmium given off   Libération plomb et cadmium   Liberación de plomo y cadmio   Abgabe von Blei und Kadmium	0 mg / dm³	0 mg / dm³	ISO 10545-15
<b>Migrazione globale</b> Overall migration   Migration globale   Migración global   Globale Migration	0 mg/dm² nessuna migrazione significativa 0 mg/dm² no significant migration	0 mg/dm² nessuna migrazione significativa 0 mg/dm² no significant migration	UNI EN 1186
<b>Emissione VOC</b> VOC emission   Emission VOC   Emisión de VOC   Emission von VOC	classe A+ francese class A+ French	classe A+ francese class A+ French	UNI EN 16000-9
<b>Resistenza alla luce</b> Light resistance   Résistance à la lumière   Resistencia a la luz   Beständigkeit gegenüber Licht	5 Nessun effetto visibile No visible effect	5 Nessun effetto visibile No visible effect	UNI EN 15187
<b>Resistenza allo shock termico</b> Thermal shock resistance   Résistance aux écarts de température   Resistencia al choque térmico   Temperaturwechselbeständigkeit	Resiste   Resistant	Resiste   Resistant	EN 14617-6
<b>Resistenza alle macchie</b> Resistance to staining   Résistance aux taches   Resistencia a las manchas   Fleckbeständigkeit	Resiste   Resistant	Resiste (nessun effetto visibile tranne inchiostro e blu di metilene) Resistant (except ink and methylene blue)	ASTM C1378

# CARATTERISTICHE TECNICHE

Technical characteristics | Caracteristiques technique | Características técnicas | Technische eigenschaften

COMPLIANCE FOR  
FOOD CONTACT  
MATERIAL  
(Conformità MOCA)



Lastre di ceramica in gres porcellanato - Gruppo Bla UGL (UNI EN 14411_G)   Porcelain stoneware slabs - Gruppe Bla UGL (UNI EN 14411_G)   Dalles en céramique en grès céram - Group Bla UGL (UNI EN 14411_G)   Losas / baldosas cerámicas de gres porcelánico - Grupo Bla UGL (UNI EN 14411_G)   Keramikplatten aus Feinsteinzeug - Groupe Bla UGL (UNI EN 14411_G)		Metodo di prova Test method Méthode d'essai Método de prueba Prüfmethode	Requisiti prescritti Required value Valeur requise Equisitos prescritos Vorgeschriebener Wert	Risultato Results Résultat Resultados Ergebnis	Valutazione Valuation Évaluation Evaluación Bewertung	
				MyTop 12 mm	MyTop 20 mm	
<b>Lunghezza e larghezza</b>   Length and width   Longueur et largeur   Longitud y anchura   Länge und Breite			± 0,6% ± 2 mm	± 0,6% ± 0,9 mm	± 0,6% ± 0,9 mm	Conforme Compliant
<b>Spessore</b>   Thickness   Epaisseur   Espesor   Stärke 12 mm - 20 mm . 4,72"-7,87"			± 5% ± 0,5 mm	± 3% ± 0,5 mm	± 3% ± 0,5 mm	Conforme Compliant
<b>Rettilineità degli spigoli</b>   Edge straightness   Rectitude des arêtes   Rectitud de los bordes   Rechtlinigkeit der Kanten	UNI EN ISO 10545-2		± 0,5% ± 1,5 mm	± 0,5% ± 1,5 mm	± 0,5% ± 1,5 mm	Conforme Compliant
<b>Ortogonalità</b>   Rectangularity   Orthogonalité   Ortogonalidad   Rechtwinkligkeit			± 0,5% ± 2 mm	± 0,5% ± 2 mm	± 0,5% ± 2 mm	Conforme Compliant
<b>Planarità</b>   Planarity   Planéité   Planaridad   Rechtwinkligkeit			± 0,5% ± 2 mm	± 0,5% ± 2 mm	± 0,5% ± 2 mm	Conforme Compliant
<b>Qualità della superficie</b>   Surface quality   Qualité de la surface   Calidad de la superficie   Oberflächenqualität			≥ 95%	Conforme Compliant	Conforme Compliant	Conforme Compliant
<b>Assorbimento d'acqua</b>   Water Absorption   Absorption d'eau   Absorción de agua   Wasseraufnahme	UNI EN ISO 10545-3  ASTM C373		≤ 0,5%  ≤ 0,5%	≤ 0,1%  ≤ 0,1%	Conforme Compliant  Conforme Compliant	Conforme Compliant  Conforme Compliant
<b>Resistenza alla flessione</b>   Bending strength   Resistance a la flexion   Resistencia a la flexión   Biegezugfestigkeit	UNI EN ISO 10545-4			<b>Modulo di rottura</b> Modulus of rupture R average ≥ 35 N/mm2	≥ 45 N  ≥ 50 N	Conforme Compliant
	UNI EN ISO 10545-4			<b>Sforzo di rottura</b> Breaking strength h ≥ 7,5 mm; S > 1300 N	≥ 1300 N  ≥ 9000 N	Conforme Compliant
<b>Resistenza all'abrasione profonda</b> Deep abrasion resistance   Résistance à l'abrasion profonde   Resistencia a la abrasión profunda   Tiefenverschleißbeständigkeit	UNI EN ISO 10545-6		≤ 175 mm³	≤ 175 mm³	≤ 175 mm³	Conforme Compliant
<b>Resistenza agli sbalzi termici</b>   Resistance to thermal shock   Résistance aux écarts de température   Resistencia a los choques térmicos   Temperaturwechselbeständigkeit	UNI EN ISO 10545-9		Resistente   Resistant	Resistente Resistant	Resistente Resistant	Conforme Compliant
<b>Resistenza al gelo</b>   Frost resistance   Résistance au gel   Resistencia al frío   Frostbeständigkeit	UNI EN ISO 10545-12		Resistente   Resistant	Ingelivo Frost proof	Ingelivo Frost proof	Conforme Compliant
<b>Resistenza all'attacco chimico</b>   Chemical resistance   Resistance a l'attaque chimique   Resistencia al ataque químico   Beständigkeit gegen chemikalien				<b>Valori dichiarati</b> Declared values B minimo   minimum	A  A	Conforme Compliant
<b>Detergenti ad uso domestico e additivi per uso piscina</b>   Household detergents and additives for swimming pools   Détergents à usage domestique et additifs pour piscines   Detergentes de uso doméstico y aditivos para piscinas   Hausreinigungsmittel und Zusatzstoffe für Schwimmbäder	UNI EN ISO 10545-13					
<b>Resistenza all'attacco chimico</b>   Chemical resistance   Resistance a l'attaque chimique   Resistencia al ataque químico   Beständigkeit gegen chemikalien	UNI EN ISO 10545-13			<b>Valori dichiarati</b> Declared values B minimo   minimum	A: LA; HA Honed,Natural Real Matt B; LB; HB 3D Texture Polished	Conforme Compliant
<b>Acidi e basi ad alta e bassa concentrazione</b>   High- and low- concentration acids and bases   Acides et bases à haute et basse concentration   Ácidos y bases de alta y baja concentración   Säuren und Basen mit hoher und niedriger Konzentration						
<b>Resistenza alle macchie</b>   Stain resistance   Resistance aux taches   Resistencia a las manchas   Fleckenbeständigkeit	UNI EN ISO 10545-14		Valori dichiarati Declared values	Classe 3-5	Classe 3-5	Conforme Compliant
<b>Resistenza dei colori alla luce</b>   Colour resistance to light exposure   Résistance des couleurs à la lumière   Resistencia del color a la exposi- ción a la luz   Farbechtheit unter Lichteinfluss	DIN 51094		Resistente   Resistant	Resistente Resistant	Resistente Resistant	Conforme Compliant
<b>Reazione al fuoco</b>   Fire reaction   Résistance au feu   Reacción al fuego   Feuerfestigkeit	UNI EN 13501-1		Resistente   Resistant	Resistente Resistant	Resistente Resistant	Conforme Compliant

\* **Valori dichiarati ottenuti da test di laboratorio. Possono subire variazioni in base al lotto produttivo.**

Stated values are obtained from laboratory tests. They may vary depending on the production batch

Valeurs déclarées basées sur des essais en laboratoire. Peuvent subir des variations en fonction du lot de production

Valores declarados obtenidos a partir de pruebas de laboratorio. Pueden sufrir variaciones según el lote de producción.

Die angegebenen Werte basieren auf Labortests. Es kann von Charge zu Charge zu Abweichungen kommen

# IMBALLI LASTRE

Slabs packaging | Emballages dalles | Embalaje | Verpackungen der Platten

## INFORMAZIONI GENERALI

General information | Informations générales | información general | Allgemeine Informationen

Lastre Mytop di Fondovalle 12 e 20 mm.

Superficie utile: 1630x3240 mm\_ 64,17"x127,56" | Spessore nominale: 12 mm.

Fondovalle's 12 and 20-mm-thick MyTop slabs.

Usable surface area: 1630x3240 mm\_ 64.17"x127.56" | Rated thickness: 12 mm.

Dalles Mytop de Fondovalle 12 et 20 mm.

Surface utile : 1630x3240 mm\_ 64,17"x127,56" | Épaisseur nominale : 12 mm.

Placas de gran formato Mytop di Fondovalle 12 y 20 mm.

Superficie útil: 1630x3240 mm\_ 64,17"x127,56" | Espesor nominal: 12 mm.

Platten Mytop von Fondovalle 12 und 20 mm.

Nutzbare Oberfläche: 1630x3240 mm\_ 64,17"x127,56" | Nennstärke: 12 mm.

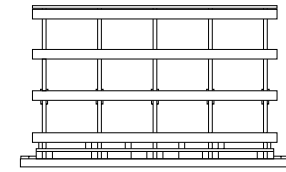

**A** Cavalletto in legno  
Wooden stand  
Support en bois  
Caballete de madera  
Gestell aus Holz  
**CAV006**

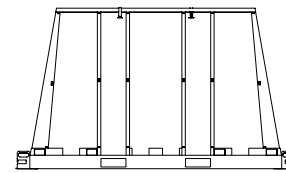

**B1** Cavalletto in metallo  
Cavalletto in metallo  
Metal A-frame  
Support en métal  
Caballete de metal  
Gestell aus Metall  
**CAV001**

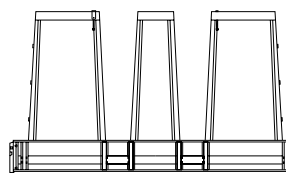

**B2** Cavalletto in metallo  
Cavalletto in metallo  
Metal A-frame  
Support en métal  
Caballete de metal  
Gestell aus Metall  
**CAV011**

Formato Cavalletto A-frame size   Format Support   Formato Caballete   Ständer format			Peso Cavalletto A-frame weight   Poids de Support   Peso del Caballete   Leergewicht der Ständer			Formato Lastre Slab size   Format Dalles   Formato de las Placas   Fliesenformat		Pezzi Pieces   Pièces   Piezas   Stücke	m <sup>2</sup>	m <sup>2</sup> / pcs.	Kg / pcs.	Kg / m <sup>2</sup>	Peso Totale Total weight   Poids total   Peso Total   Leergewicht gesamt
<b>CAV001</b>	<b>CAV006</b>	<b>CAV011</b>	<b>CAV001</b>	<b>CAV006</b>	<b>CAV011</b>	<b>12 mm</b>	22	116,1864	5,2812	151,11	28,62	3325 Kg + 189 Kg	
330x75x198 cm 130"x30"x78"	330x75x196,8 cm 130"x30"x78"	338,6x75x185,7 cm 133"x30"x73"	133 Kg 294 lb	166 Kg 365 lb	123 Kg 271 lb	<b>20 mm</b>	12	63,38	5,2812	253,44	47,99	3041,28 Kg + 189 Kg	

# COMPOSIZIONE CARICO

Load layout | Composition du chargement | Composición de la carga | Zusammensetzung der Bestandteile

## EXAMPLES

Container 20' 163x324 - 12 mm

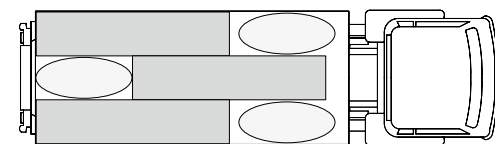

Container 40' 163x324 - 12 mm

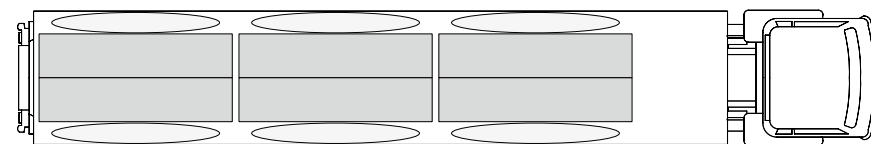

Truck 2,4x13 - 163x324 - 12 mm (es. Truck 30 Ton.)

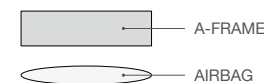
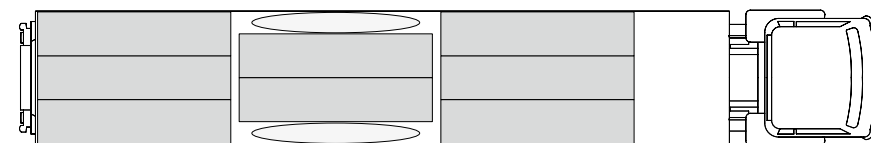

# BORDI

Edges | Bords | Cantos | Kanten

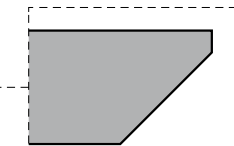
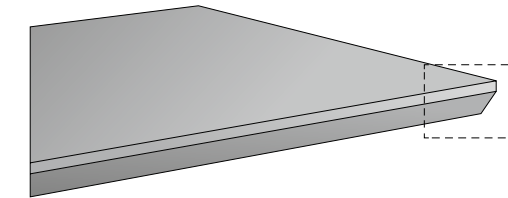

**Costa 45° squadrata (Ail d'Avion)**  
Squared ridge at 45°  
Côte à 45° carrée  
Canto a 45° recto  
Quadratische 45°-rippe

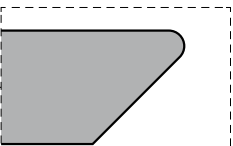

**Costa 45° arrotondata**  
Rounded ridge at 45°  
Côte à 45° arrondie  
Canto a 45° redondeado  
Abgerundete 45°-rippe

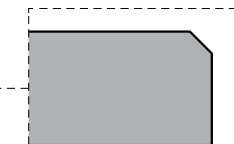
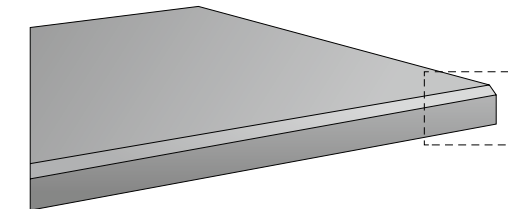

**Costa retta squadrata**  
Straight squared ridge  
Côte droit carrée  
Canto recto doble y cuadrado  
Quadratische gerade rippe



**Costa retta arrotondata**  
Rounded straight ridge  
Côte droit arrondie  
Canto redondo y cuadrado  
Abgerundete gerade rippe

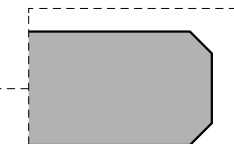
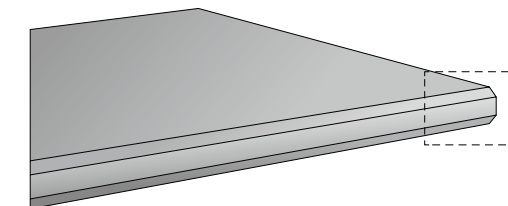

**Costa retta doppia squadrata**  
Double straight squared ridge  
Côte droit double carrée  
Canto recto doble y cuadrado  
Quadratische gerade doppelrippe

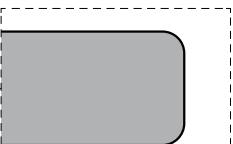

**Costa retta doppia arrotondata**  
Double straight rounded ridge  
Côte droit double arrondie  
Canto redondo doble y cuadrado  
Abgerundete gerade doppelrippe

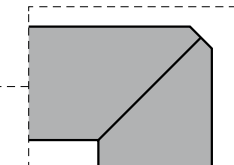
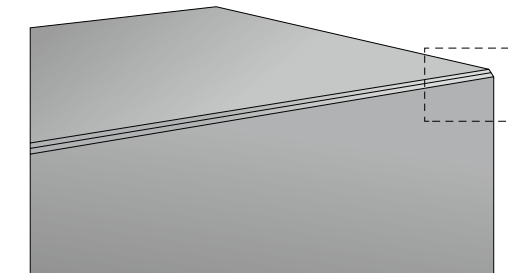

**Costa elle squadrata**  
L-shaped squared ridge  
Côte en L carrée  
Canto ingletado recto  
Quadratische L-rippe

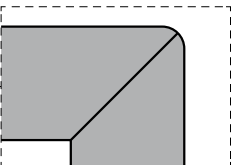

**Costa elle arrotondata**  
L-shaped rounded ridge  
Côte en L arrondie  
Canto ingletado redondo  
Abgerundete L-rippe

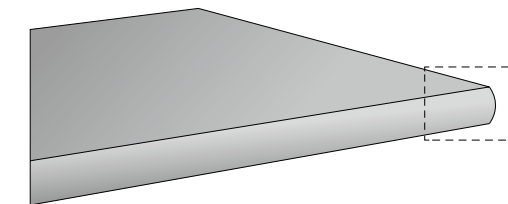

**Costa a toro**  
Bullnose edge  
Bord arrondi  
Canto redondeado  
Abgerundete Kante



Ceramics of Italy

AD: Marketing Dept.

01/2026

© Ceramica Fondovalle S.p.A.

È vietata la riproduzione, totale e parziale del catalogo in tutte le sue forme.

Reproduction of this printed catalogue totally or partially, is forbidden.

Ceramica Fondovalle si riserva di apportare, qualora lo ritenesse opportuno, eventuali modifiche di natura tecnica o formale ai dati riportati in questo strumento. I colori sono puramente indicativi.

Ceramica Fondovalle reserves the right, when it deems necessary, to make technical and formal changes to the data included herein. The colours are purely illustrative.

# FONDOVALLE

**Ceramica Fondovalle S.p.A.**

Via Rio Piodo, 12  
41053 Torre Maina, (MO) Italy  
T. +39 0536 934211  
F. +39 0536 934250  
[www.fondovalle.it](http://www.fondovalle.it)

A company part of



**Sustainability®**  
Award

**ITALCER - WINNER OF THE  
2022 SUSTAINABILITY AWARD**



